

TBM™ Frameless Motor Selection Guide

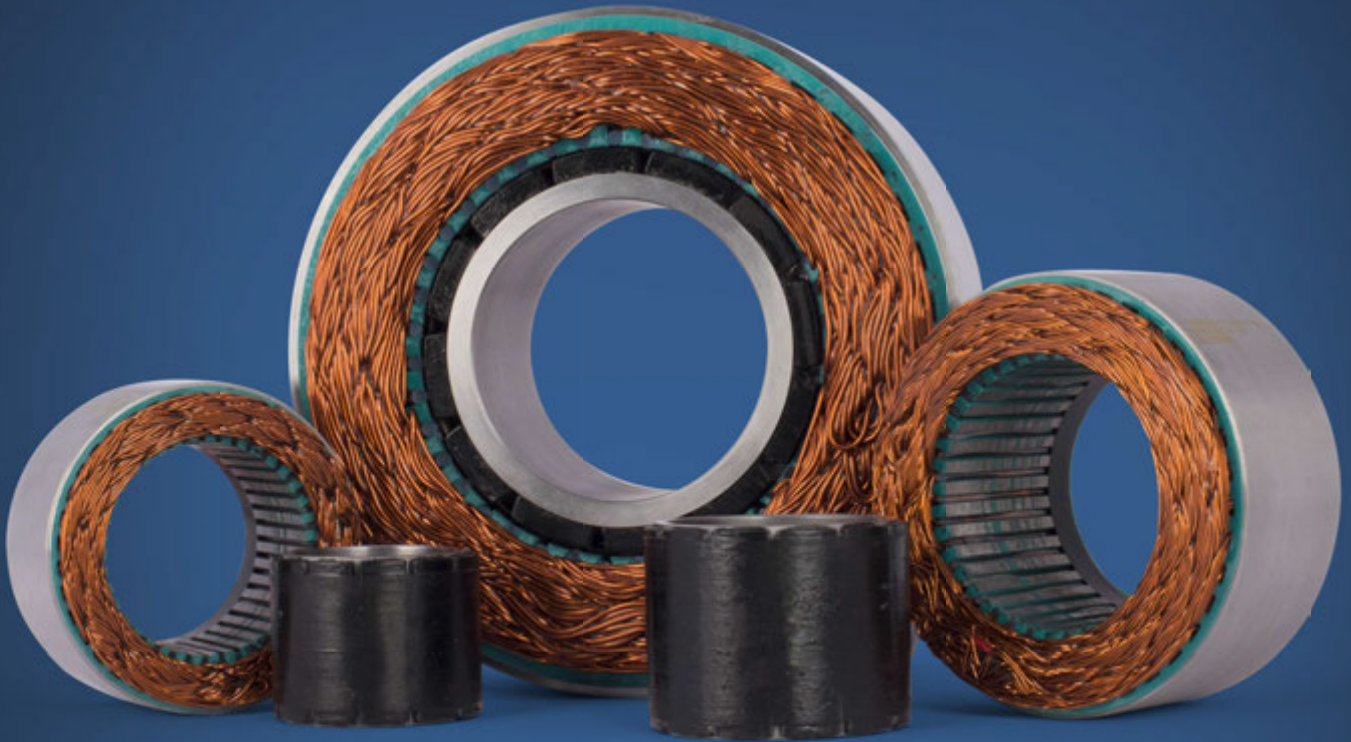

KOLLMORGEN®

Because Motion Matters™

Because Motion Matters™

Table of Contents

- ▶ **TBM™ Series Frameless Motor** 3
- ▶ **TBM(S)™ 60 Series Motor**
 - TBM(S) 60 Outline Drawings 4
 - TBM(S) 60 Performance Data and Parameters 5
 - TBM(S) 60 Performance Curves 6
- ▶ **TBM(S)™ 76 Series Motor**
 - TBM(S) 76 Outline Drawings 8
 - TBM(S) 76 Performance Data and Parameters 9
 - TBM(S) 76 Performance Curves 10
- ▶ **TBM(S)™ 129 Series Motor**
 - TBM(S) 129 Outline Drawings 12
 - TBM(S) 129 Performance Data and Parameters 13
 - TBM(S) 129 Performance Curves 14
- ▶ **Connection Diagrams** 16
- ▶ **Model Nomenclature** 17
- ▶ **Available TBM(S) Modifications** 17

Removing the Barriers of Design, Sourcing, and Time

At Kollmorgen, we know that OEM engineers can achieve a lot more when obstacles aren't in the way. So, we clear obstacles in three important ways:

Integrating Standard and Custom Products

The optimal solution is often not clear-cut. Our application expertise allows us to modify standard products or develop totally custom solutions across our whole product portfolio so that designs can take flight.

Providing Motion Solutions, Not Just Components

As companies reduce their supplier base and have less engineering manpower, they need a total system supplier with a wide range of integrated solutions. Kollmorgen offers complete solutions as well as motion subsystems that combine programming software, engineering services and best-in-class motion components.

Global Footprint

With direct sales, engineering support, manufacturing facilities, and distributors spanning the Americas, Europe, Middle East, and Asia, we're close to OEMs worldwide. Our proximity helps speed delivery and lend support where and when they're needed.

Financial and Operational Stability

Kollmorgen is part of Fortive. A key driver in the growth of all Fortive divisions is the Fortive Business System, which relies on the principle of "kaizen" – or continuous improvement. Using world-class tools, cross-disciplinary teams of exceptional people evaluate processes and develop plans that result in superior performance.

Kollmorgen: Your partner. In Motion.

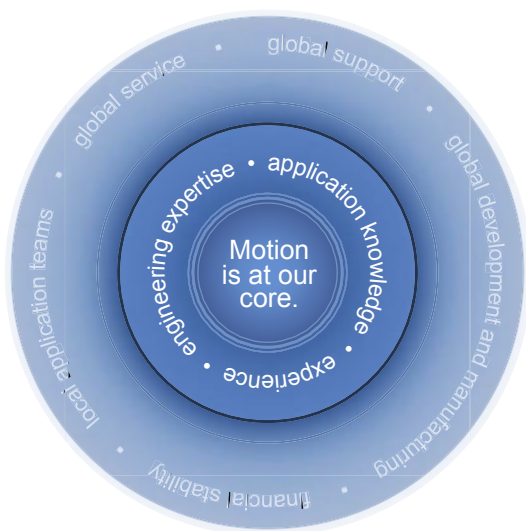

TBM™ Series Frameless Motor

The TBM frameless motor is a new series of direct drive torque motors designed for applications that require high power in a small, compact form factor with minimized weight and inertia.

Typical applications include robotic joints, weapon stations, sensor gimbals, sight systems, UAV propulsion and guidance, as well as many others.

TBM(S) Product Features

- 3 frame sizes ranging from 60mm (2.36 inches) up to 129mm (5.08 inches)
- 3 stacks lengths per frame
- 2 standard winding options per frame
- Latching Hall Effects (pre-aligned / factory installed)
- Low Cogging designs
- Stainless Steel Yokes for maximum corrosion protection
- RoHS Compliant
- Banded Rotors
- Laser Marked Armatures

For non-standard requests Kollmorgen provides a variety of standard options and configurations.

If higher levels of customization are required, contact Kollmorgen to help us understand exactly what you need.



TBM 60 Series Outline Drawings

TBM 60

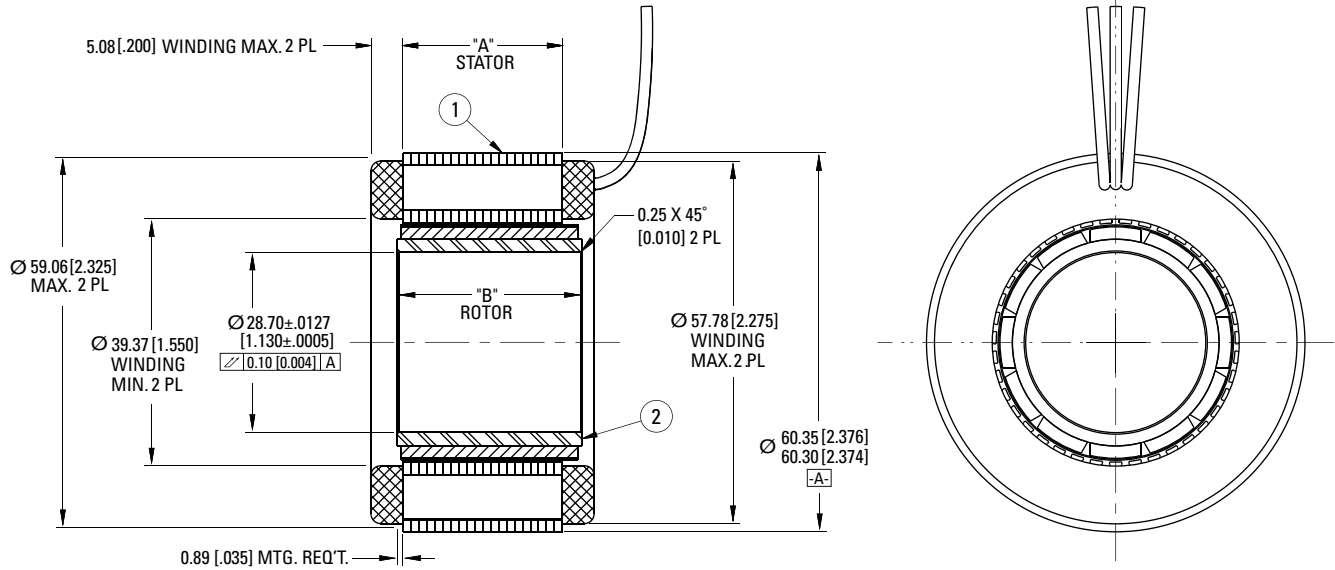

TBMS 60

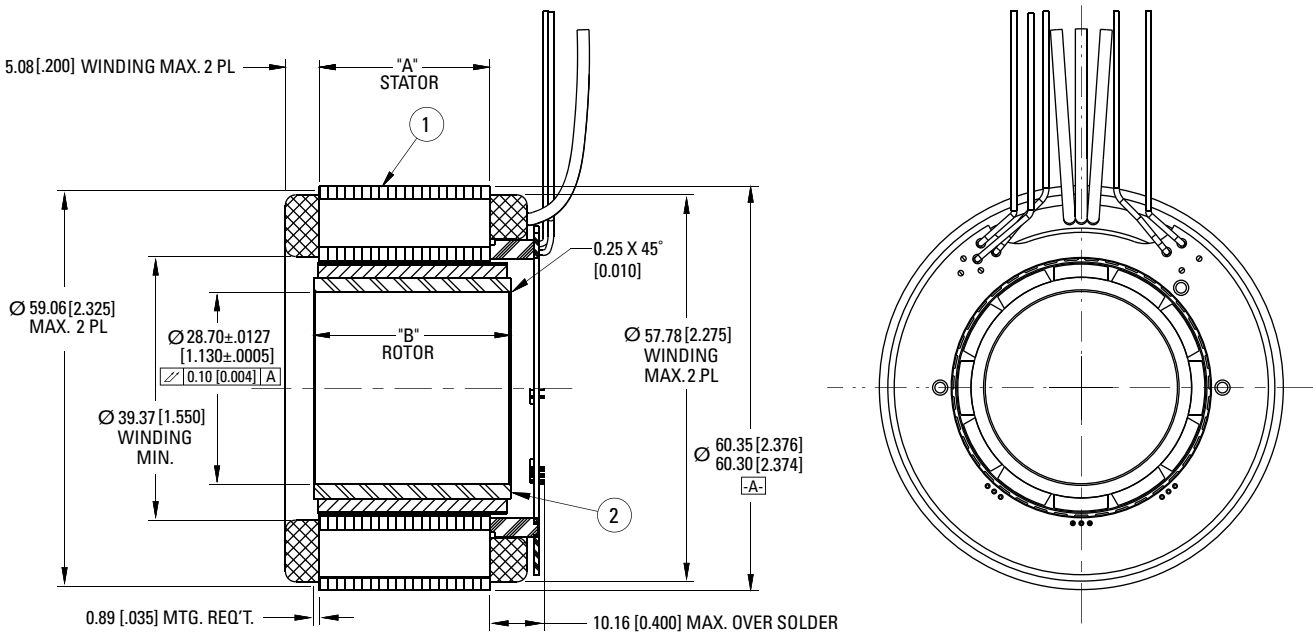

MOTOR LEADS:

#20 AWG, TEFLON® COATED, PER MIL-W-22759/11
 3 LEADS - 400 [15.75] MIN. LONG EACH
 1-RED, 1-WHITE, & 1-BLACK
 MIN. MOTOR LEAD BEND RADIUS 7.62 [0.30]

SENSOR LEADS:

#26 AWG, TYPE "ET", TEFLON® COATED, PER MIL-W-16878
 5 LEADS 400 [15.75] MIN. LONG EACH
 1-BLUE, 1-BROWN, 1-GREEN, 1-ORANGE, & 1-YELLOW
 MIN. SENSOR LEAD BEND RADIUS 3.90 [0.15]

Notes:

- All dimensions are in mm [inches]
- Motor supplied as two separate components: ① armature & sensor assembly and ② field assembly

MODEL NUMBER	"A" mm [inch]	"B" mm [inch]
TBM(S)-6013	12.70 ± 0.25 [0.500 ± 0.01]	16.76 [0.660]
TBM(S)-6025	25.40 ± 0.25 [1.000 ± 0.01]	29.46 [1.160]
TBM(S)-6051	50.80 ± 0.25 [2.000 ± 0.01]	54.86 [2.160]

TBM 60 Series Performance Data

TBM(S) 60 Series Performance Data and Motor Parameters

Motor Parameter	Symbol	Units	TOL	TBM(S)-6013-X		TBM(S)-6025-X		TBM(S)-6051-X	
				A	B	A	B	A	B
Continuous Stall Torque*	Tc	N-m	NOM	0.415	0.390	0.727	0.694	1.08	0.925
		oz-in		58.8	55.2	103	98.3	153	131
Continuous Current	Ic	Adc	NOM	5.51	8.30	5.58	9.33	6.54	9.33
		Arms		4.50	6.78	4.56	7.62	5.48	7.62
Peak Stall Torque* (25°C winding temp)	Tp	N-m	NOM	1.39	1.23	2.82	2.56	5.08	3.53
		oz-in		197	174	400	363	720	500
Peak Current	Ip	Adc	NOM	19.0	26.9	21.3	33.9	30.0	33.9
		Arms		15.5	22.0	17.4	27.7	24.5	27.7
Rated Cont Power*	P Rated	Watts	NOM	114	103	144	125	159	135
Speed at Rated Power	N Rated	RPM	NOM	4000	3540	2630	2250	2065	1600
Design Voltage	Vbus	Vdc	NOM	48.0	24.0	48.0	24.0	48.0	24.0
	Vac	Vrms	NOM	33.9	17.0	33.9	17.0	33.9	17.0
Torque Sensitivity at Temp*	Kt (hot)	N-m / Adc	+/-10%	0.079	0.049	0.135	0.078	0.176	0.106
		oz-in / Adc		11.2	7.00	19.1	11.0	24.9	14.9
		N-m / Arms	+/-10%	0.097	0.061	0.165	0.095	0.215	0.129
		oz-in / Arms		13.7	8.57	23.4	13.5	30.5	18.3
Back EMF at Temp*	Kb (hot)	Vpk / kRPM	+/-10%	8.28	5.18	14.1	8.13	18.4	11.0
		Vrms / kRPM		5.86	3.66	9.99	5.75	13.0	7.81
Torque Sensitivity at 25°C	Kt (cold)	N-m / Adc	+/-10%	0.087	0.054	0.148	0.085	0.193	0.116
		oz-in / Adc		12.3	7.70	21.0	12.1	27.4	16.4
		N-m / Arms	+/-10%	0.107	0.067	0.182	0.105	0.237	0.142
		oz-in / Arms		15.1	9.43	25.7	14.8	33.5	20.1
Back EMF	Kb (cold)	Vpk / kRPM	+/-10%	9.11	5.69	15.5	8.95	20.3	12.2
		Vrms / kRPM		6.44	4.03	11.0	6.33	14.3	8.59
Motor Constant at 25°C	Km (cold)	N-m/√watt	+/-10%	0.097	0.091	0.157	0.152	0.230	0.212
		oz-in/√watt		13.7	12.9	22.3	21.5	32.6	30.0
Motor Constant at Temp	Km (hot)	N-m/√watt	+/-10%	0.072	0.068	0.117	0.112	0.164	0.161
		oz-in/√watt		10.2	9.59	16.5	15.9	23.3	22.7
Resistance at 25°C	Rm	Ohms	+/- 10%	0.804	0.355	0.890	0.318	0.763	0.288
Inductance	Lm	mH	+/- 30%	0.39	0.15	0.60	0.20	0.60	0.22
Inertia*	Jm	Kg-m ²		1.41E-05		2.52E-05		4.75E-05	
		oz-in-s ²		2.00E-03		3.57E-03		6.72E-03	
Weight*	Wt	grams		221		398		571	
		oz		7.77		14.0		20.1	
Max Static Friction	Tf	N-m		0.021		0.033		0.056	
		oz-in		2.93		4.62		8.00	
Cogging Friction (Peak-to-Peak)	Tcog	N-m		0.009		0.012		0.019	
		oz-in		1.22		1.71		2.70	
Viscous Damping	Fi	N-m / kRPM		2.04E-03		5.36E-03		1.14E-02	
		oz-in / kRPM		2.88E-01		7.59E-01		1.62	
Thermal Resistance*	TPR	°C / watt		3.55		3.13		2.72	
Number of Poles	P	-		12		12		12	

***Notes**

- 1) Continuous Stall Torque and Rated Power assume ambient temperature of 25°C
- 2) Winding temp = 155°C for Kt and Kb hot
- 3) Inertia and weight assume max thru-bore
- 4) TPR assumes motor is housed and mounted to a 3.5" x 3.5" x 0.25" heat sink or equivalent
- 5) Some Peak and Continuous Torques may be limited by lead wire gauge

TBM 60 Series Performance Curves

TBM(S)-6013-A
48 Vdc – 6 step

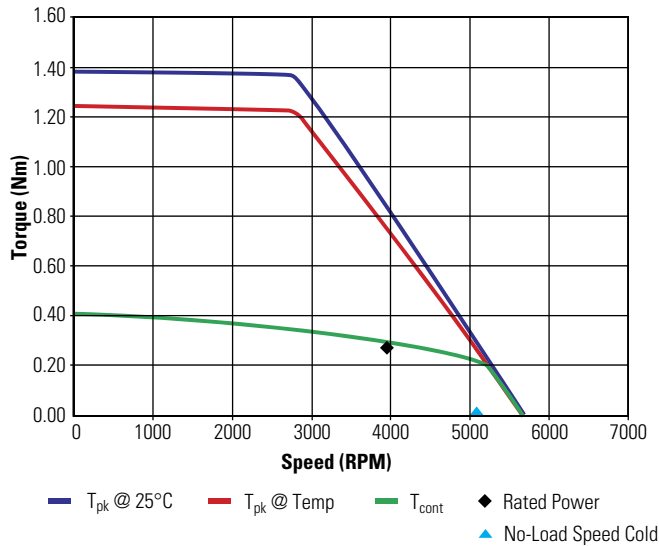

TBM(S)-6013-B
24 Vdc – 6 step

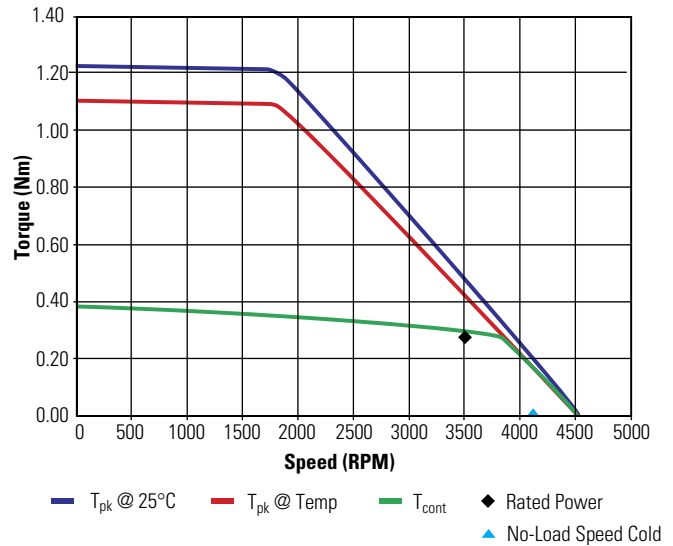

TBM(S)-6025-A
48 Vdc – 6 step

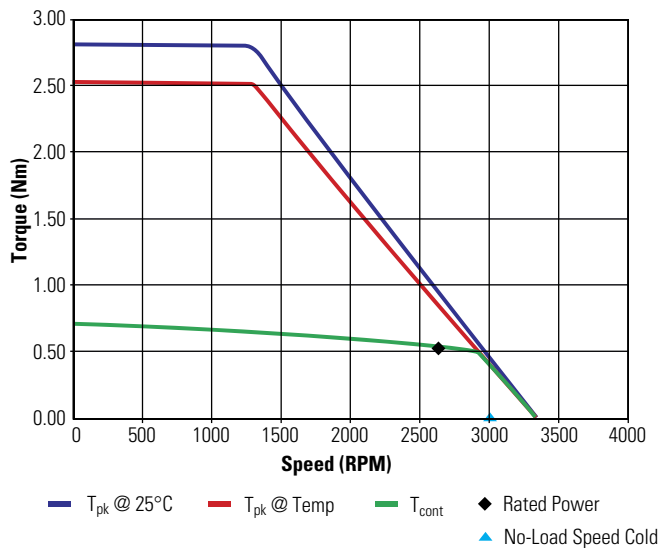

TBM(S)-6025-B
24 Vdc – 6 step

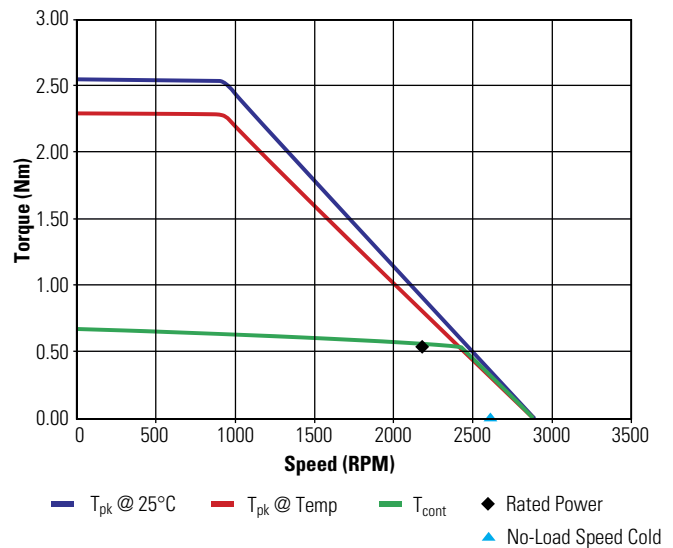

TBM(S)-6051-A
48 Vdc – 6 step

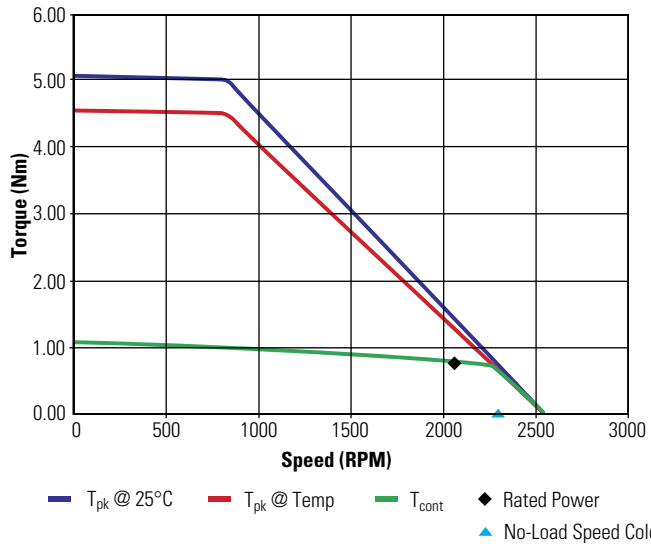

TBM(S)-6051-B
24 Vdc – 6 step

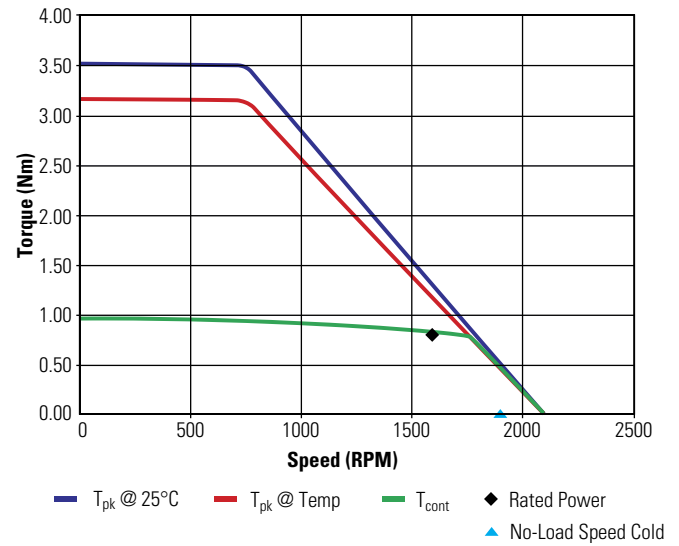

Notes:

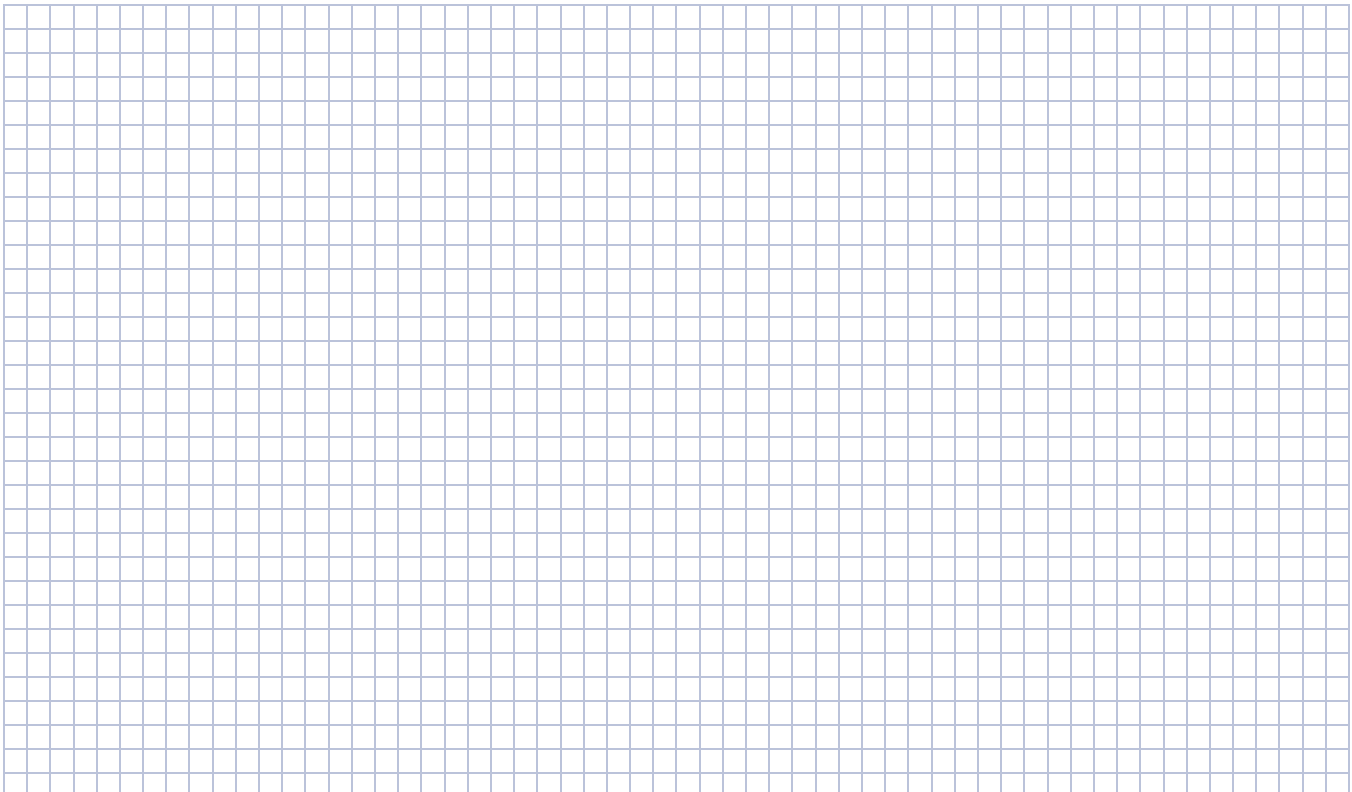

TBM 76 Series Outline Drawings

TBM 76

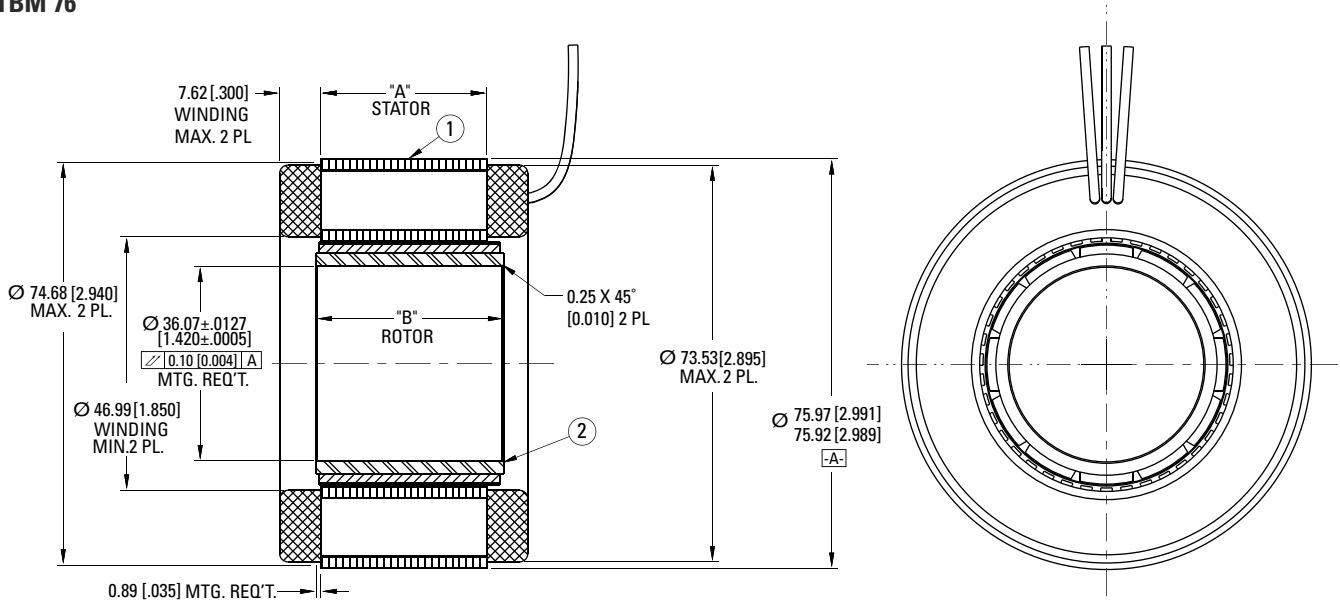

TBMS 76

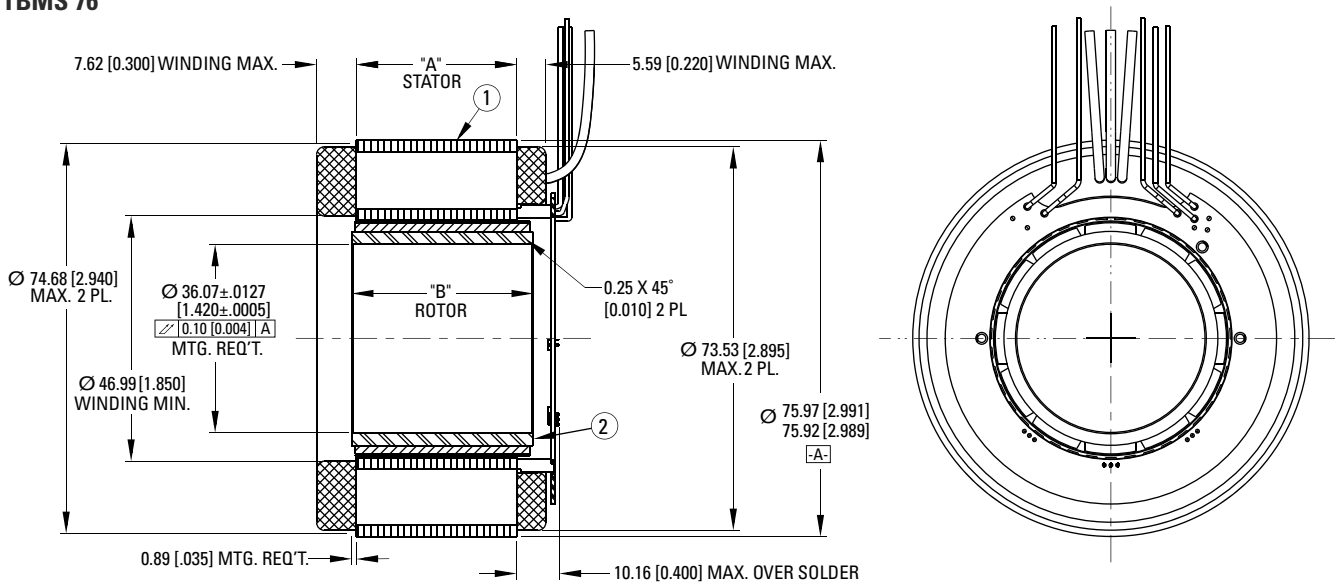

MOTOR LEADS:

#18 AWG, TEFLON® COATED, PER MIL-W-22759/11
 3 LEADS - 400 [15.75] MIN. LONG EACH
 1-RED, 1-WHITE, & 1-BLACK
 MIN. MOTOR LEAD BEND RADIUS 6.90 [0.27]

SENSOR LEADS:

#26 AWG, TYPE "ET", TEFLON® COATED, PER MIL-W-16878
 5 LEADS 400 [15.75] MIN. LONG EACH
 1-BLUE, 1-BROWN, 1-GREEN, 1-ORANGE, & 1-YELLOW
 MIN. SENSOR LEAD BEND RADIUS 3.90 [0.15]

Notes:

- All dimensions are in mm [inches]
- Motor supplied as two separate components: ① armature & sensor assembly and ② field assembly

MODEL NUMBER	"A" mm [inch]	"B" mm [inch]
TBM(S)-7615	15.24 ±0.25 [0.600 ±0.01]	19.30 [0.760]
TBM(S)-7631	30.73 ±0.25 [1.210 ±0.01]	38.40 [1.370]
TBM(S)-7646	46.23 ±0.25 [1.820 ±0.01]	50.29 [1.980]

TBM 76 Series Performance Data

TBM(S) 76 Series Performance Data and Motor Parameters

Motor Parameter	Symbol	Units	TOL	TBM(S)-7615-X		TBM(S)-7631-X		TBM(S)-7646-X	
				A	B	A	B	A	B
Continuous Stall Torque*	Tc	N-m	NOM	0.939	0.918	1.65	1.64	2.18	2.13
		oz-in		133	130	234	232	309	302
Continuous Current	Ic	Adc	NOM	10.5	14.3	10.9	13.0	11.8	14.4
		Arms		8.57	11.7	8.90	10.6	9.63	11.8
Peak Stall Torque* (25°C winding temp)	Tp	N-m	NOM	3.04	2.22	5.37	4.60	6.74	5.51
		oz-in		430	315	760	652	955	780
Peak Current	Ip	Adc	NOM	36.0	36.0	36.0	36.0	36.0	36.0
		Arms		29.4	29.4	29.4	29.4	29.4	29.4
Rated Cont Power*	P Rated	Watts	NOM	258	208	307	190	335	217
Speed at Rated Power	N Rated	RPM	NOM	3930	2560	2300	1210	1850	1025
Design Voltage	Vbus	Vdc	NOM	48.0	24.0	48.0	24.0	48.0	24.0
	Vac	Vrms	NOM	33.9	17.0	33.9	17.0	33.9	17.0
Torque Sensitivity at Temp*	Kt (hot)	N-m / Adc	+/-10%	0.093	0.066	0.156	0.130	0.192	0.153
		oz-in / Adc		13.1	9.36	22.1	18.4	27.1	21.7
		N-m / Arms	+/-10%	0.113	0.081	0.191	0.159	0.235	0.188
		oz-in / Arms		16.0	11.5	27.1	22.5	33.2	26.6
Back EMF at Temp*	Kb (hot)	Vpk / kRPM	+/-10%	9.69	6.92	16.3	13.6	20.1	16.0
		Vrms / kRPM		6.85	4.89	11.56	9.62	14.2	11.3
Torque Sensitivity at 25°C	Kt (cold)	N-m / Adc	+/-10%	0.102	0.073	0.172	0.143	0.211	0.169
		oz-in / Adc		14.4	10.3	24.3	20.2	29.9	23.9
		N-m / Arms	+/-10%	0.125	0.089	0.210	0.175	0.258	0.206
		oz-in / Arms		17.6	12.6	29.8	24.8	36.6	29.2
Back EMF	Kb (cold)	Vpk / kRPM	+/-10%	10.7	7.61	18.0	15.0	22.1	17.7
		Vrms/kRPM		7.53	5.38	12.7	10.6	15.6	12.48
Motor Constant at 25°C	Km (cold)	N-m/√watt	+/-10%	0.167	0.169	0.272	0.279	0.360	0.341
		oz-in/√watt		23.7	23.9	38.5	39.5	51.0	48.2
Motor Constant at Temp	Km (hot)	N-m/√watt	+/-10%	0.124	0.121	0.202	0.200	0.252	0.253
		oz-in/√watt		17.6	17.1	28.6	28.3	35.6	35.8
Resistance at 25°C	Rm	Ohms	+/- 10%	0.370	0.200	0.398	0.281	0.387	0.245
Inductance	Lm	mH	+/- 30%	0.40	0.20	0.60	0.42	0.63	0.40
Inertia*	Jm	Kg-m ²		3.04E-05		5.64E-05		8.19E-05	
		oz-in-s ²		4.31E-03		7.98E-03		1.16E-02	
Weight*	Wt	grams		435		738		1079	
		oz		15.3		26.0		38.0	
Max Static Friction	Tf	N-m		0.032		0.050		0.068	
		oz-in		4.49		7.09		9.70	
Cogging Friction (Peak-to-Peak)	Tcog	N-m		0.013		0.017		0.020	
		oz-in		1.79		2.35		2.90	
Viscous Damping	Fi	N-m/ kRPM		6.05E-03		1.60E-02		2.81E-02	
		oz-in / kRPM		8.57E-01		2.27		3.98	
Thermal Resistance*	TPR	°C / watt		2.11		1.83		1.62	
Number of Poles	P	-		12		12		12	

*Notes

- 1) Continuous Stall Torque and Rated Power assume ambient temperature of 25°C
- 2) Winding temp = 155°C for Kt and Kb hot
- 3) Inertia and weight assume max thru-bore
- 4) TPR assumes motor is housed and mounted to a 7.0" x 7.5" x 0.375" heat sink or equivalent
- 5) Peak Torques limited by lead wire gauge

TBM 76 Series Performance Curves

TBM(S)-7615-A
48 Vdc – 6 step

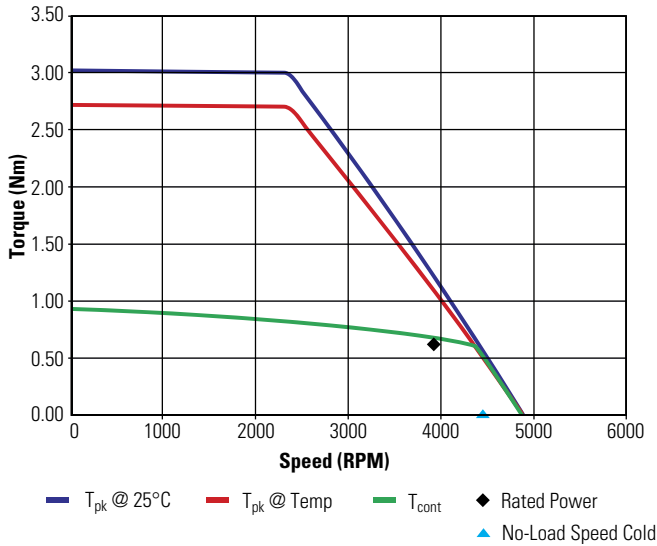

TBM(S)-7615-B
24 Vdc – 6 step

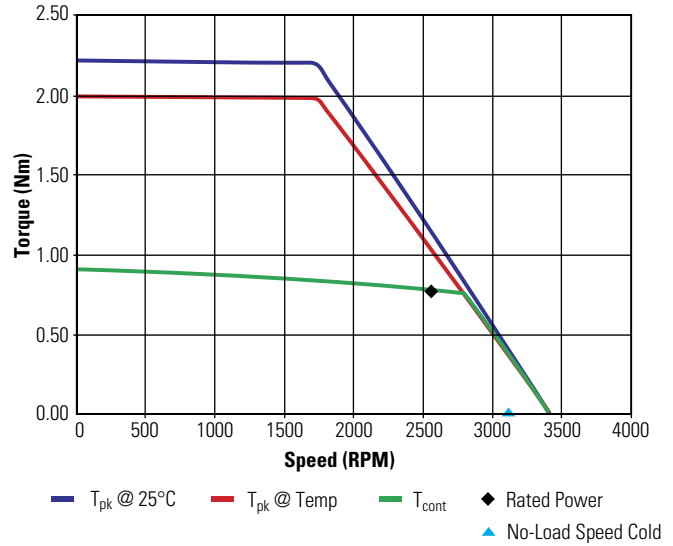

TBM(S)-7631-A
48 Vdc – 6 step

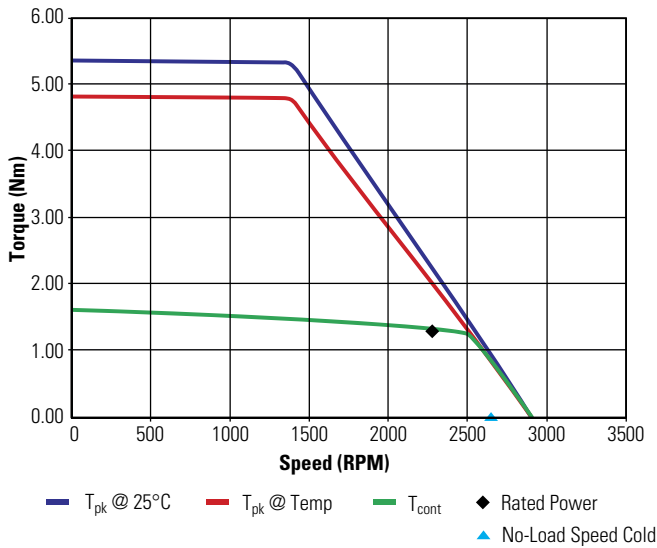

TBM(S)-7631-B
24 Vdc – 6 step

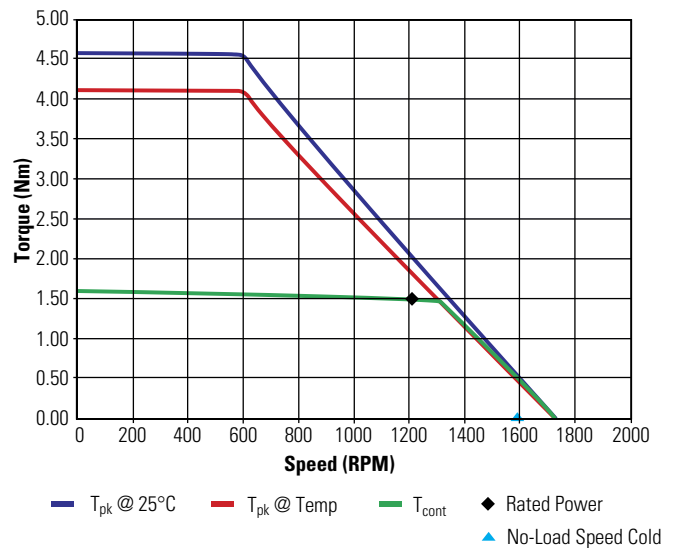

TBM(S)-7646-A
48 Vdc – 6 step

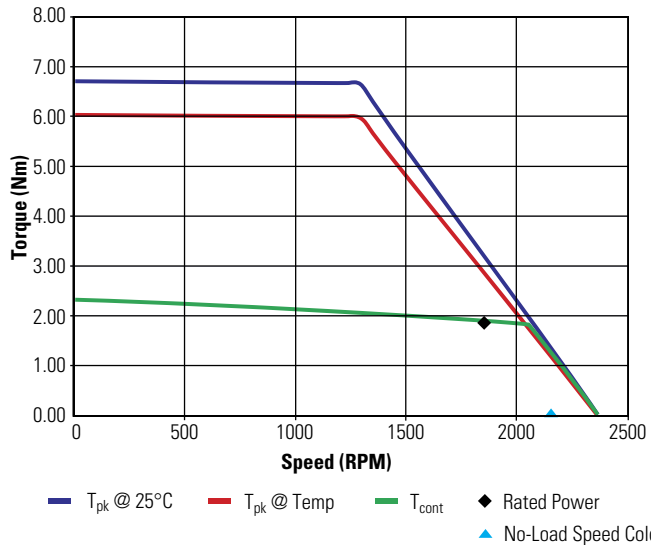

TBM(S)-7646-B
24 Vdc – 6 step

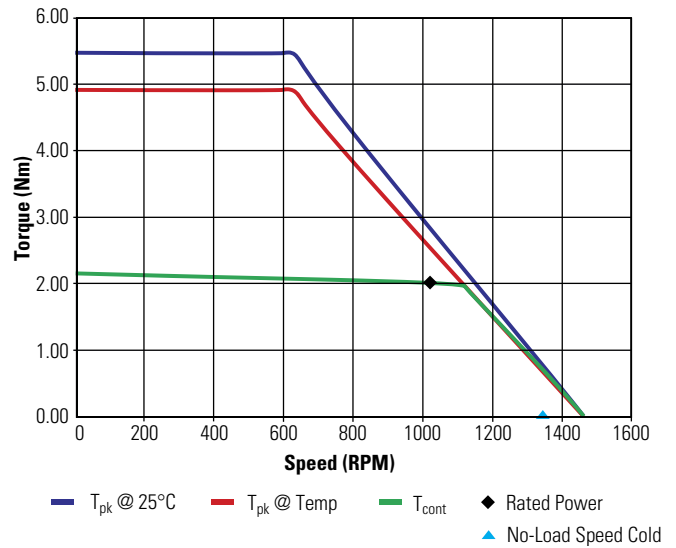

Notes:

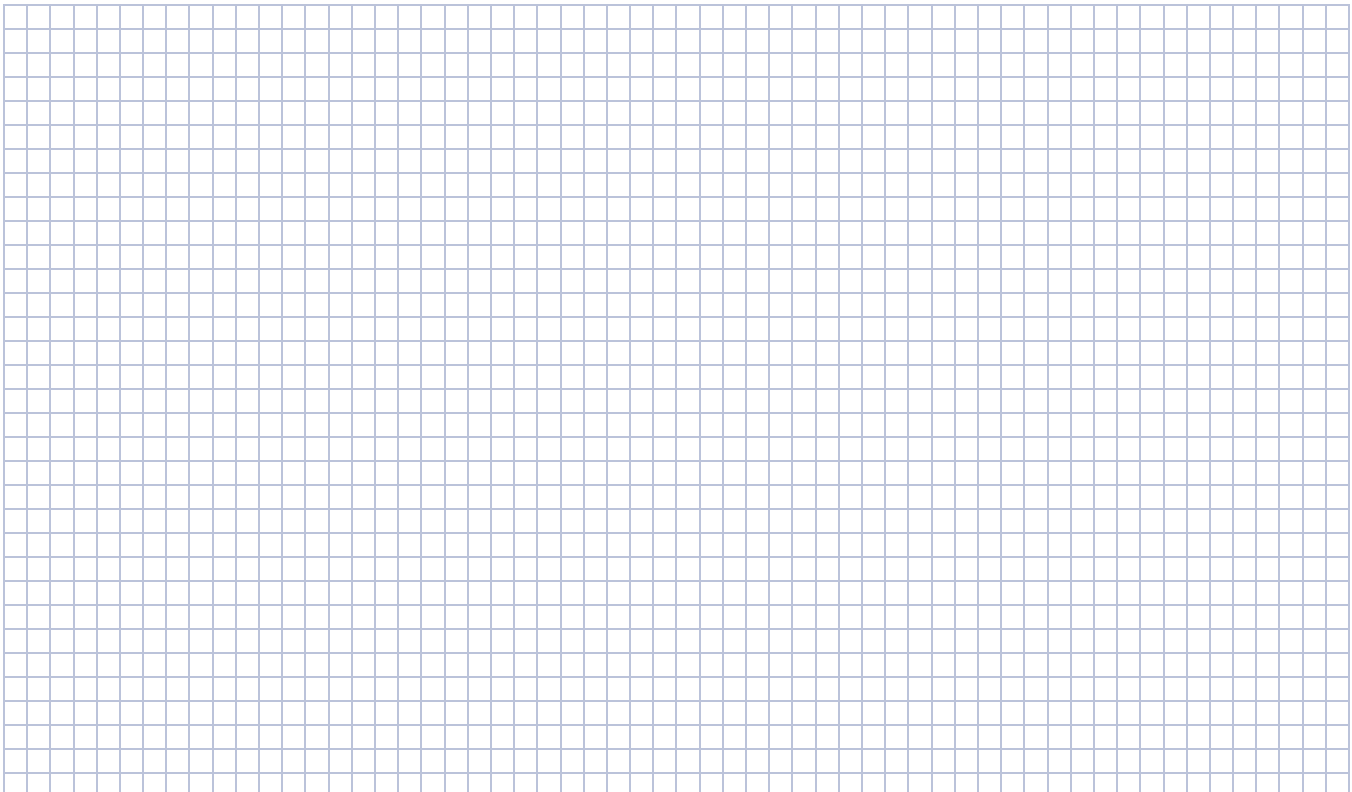

TBM 129 Series Outline Drawings

TBM 129

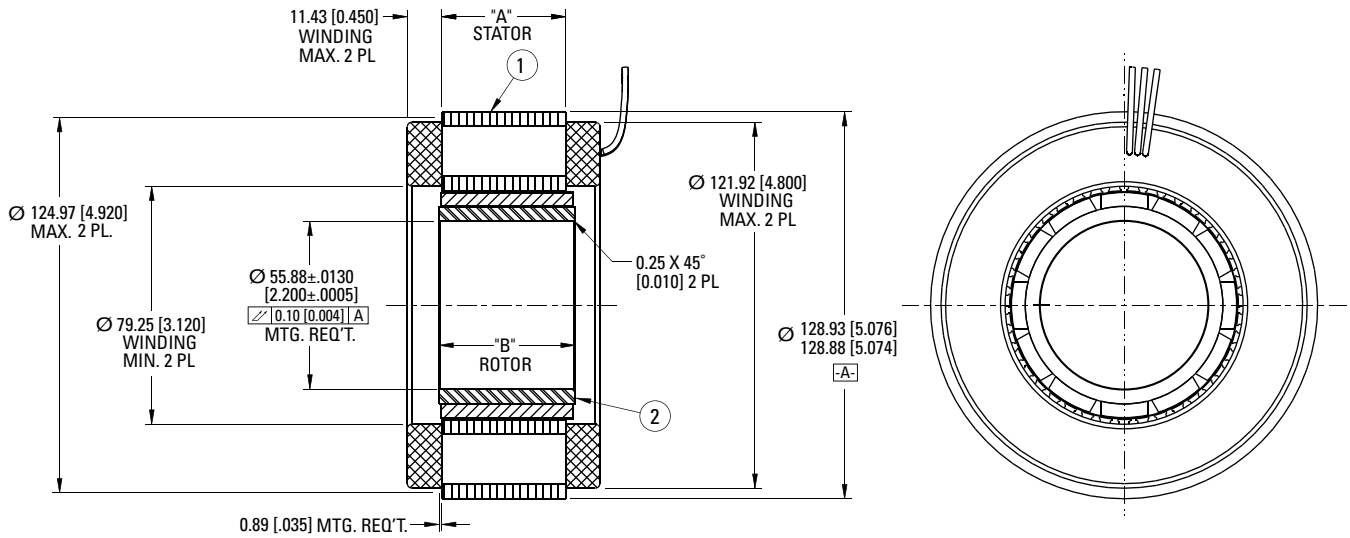

TBMS 129

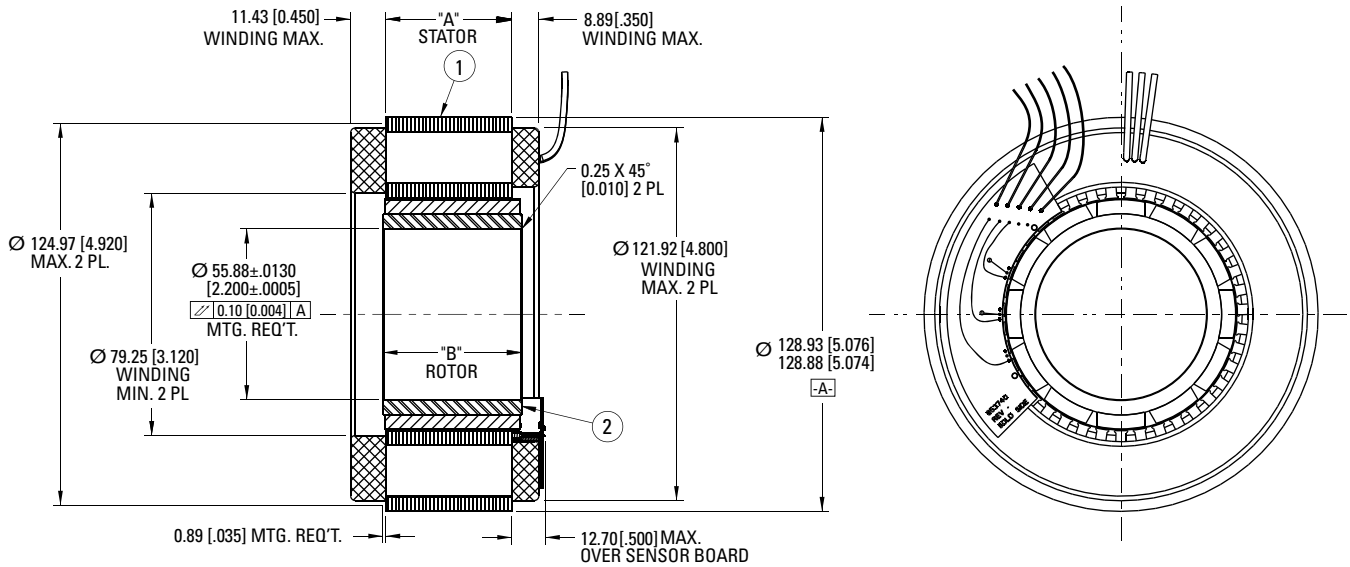

MOTOR LEADS:

#16 AWG, TEFLON® COATED, PER MIL-W-22759/11
 3 LEADS - 400 [15.75] MIN. LONG EACH
 1-RED, 1-WHITE, & 1-BLACK
 MIN. MOTOR LEAD BEND RADIUS 7.62 [0.30]

SENSOR LEADS:

#26 AWG, TYPE "ET", TEFLON® COATED, PER MIL-W-16878
 5 LEADS 400 [15.75] MIN. LONG EACH
 1-BLUE, 1-BROWN, 1-GREEN, 1-ORANGE, & 1-YELLOW
 MIN. SENSOR LEAD BEND RADIUS 3.90 [0.15]

Notes:

1. All dimensions are in mm [inches]
2. Motor supplied as two separate components: ① armature & sensor assembly and ② field assembly

MODEL NUMBER	"A" mm [inch]	"B" mm [inch]
TBM(S)-12913	13.33 ± 0.25 [0.525 ± 0.01]	17.40 [0.685]
TBM(S)-12941	41.28 ± 0.25 [1.625 ± 0.01]	45.35 [1.785]
TBM(S)-12955	54.61 ± 0.25 [2.150 ± 0.01]	58.67 [2.310]

TBM 129 Series Performance Data

TBM(S) 129 Series Performance Data and Motor Parameters

Motor Parameter	Symbol	Units	TOL	TBM(S)-12913-X		TBM(S)-12941-X		TBM(S)-12955-X	
				A	B	A	B	A	B
Continuous Stall Torque*	Tc	N-m	NOM	2.87	2.89	8.30	7.66	10.4	9.88
		Lb-Ft		2.12	2.13	6.12	5.65	7.69	7.29
Continuous Current	Ic	Adc	NOM	12.5	20.8	17.0	18.3	16.3	18.1
		Arms		10.2	17.0	13.9	14.9	13.3	14.8
Peak Stall Torque* (25°C winding temp)	Tp	N-m	NOM	11.0	7.36	27.1	24.4	36.2	31.0
		Lb-Ft		8.12	5.43	20.0	18.0	26.7	22.8
Peak Current	Ip	Adc	NOM	57.0	57.0	57.0	57.0	57.0	57.0
		Arms		46.5	46.5	46.5	46.5	46.5	46.5
Rated Cont Power*	P Rated	Watts	NOM	505	505	865	830	920	585
Speed at Rated Power	N Rated	RPM	NOM	2490	2505	1520	580	1190	625
Design Voltage	Vbus	Vdc	NOM	100	48.0	100	48.0	100	48.0
	Vac	Vrms	NOM	70.7	33.9	70.7	33.9	70.7	33.9
Torque Sensitivity at Temp*	Kt (hot)	N-m / Adc	+/-10%	0.241	0.145	0.509	0.437	0.666	0.572
		Lb-Ft / Adc		0.178	0.107	0.376	0.322	0.492	0.422
		N-m / Arms	+/-10%	0.296	0.177	0.624	0.535	0.816	0.701
		Lb-Ft / Arms		0.218	0.131	0.460	0.394	0.602	0.517
Back EMF at Temp*	Kb (hot)	Vpk / kRPM	+/-10%	25.3	15.2	53.3	45.7	69.8	59.9
		Vrms / kRPM		17.9	10.7	37.7	32.3	49.3	42.4
Torque Sensitivity at 25°C	Kt (cold)	N-m / Adc	+/-10%	0.265	0.159	0.560	0.480	0.733	0.629
		Lb-Ft / Adc		0.196	0.117	0.413	0.354	0.541	0.464
		N-m / Arms	+/-10%	0.325	0.195	0.686	0.588	0.898	0.771
		Lb-Ft / Arms		0.240	0.144	0.506	0.434	0.662	0.569
Back EMF	Kb (cold)	Vpk / kRPM	+/-10%	27.8	16.7	58.6	50.3	76.8	65.9
		Vrms/kRPM		19.7	11.8	41.5	35.6	54.3	46.6
Motor Constant at 25°C	Km (cold)	N-m/√watt	+/-10%	0.443	0.460	1.12	1.10	1.35	1.33
		Lb-Ft/√watt		0.327	0.339	0.826	0.811	1.00	0.980
Motor Constant at Temp	Km (hot)	N-m/√watt	+/-10%	0.328	0.329	0.831	0.769	1.02	0.968
		oz-in/√watt		0.242	0.243	0.613	0.567	0.75	0.714
Resistance at 25°C	Rm	Ohms	+/- 10%	0.360	0.129	0.250	0.215	0.286	0.233
Inductance	Lm	mH	+/- 30%	0.60	0.22	0.92	0.68	1.2	0.88
Inertia*	Jm	Kg-m ²		2.71E-04		7.21E-04		9.37E-04	
		Lb-Ft-s ²		2.00E-04		5.32E-04		6.91E-04	
Weight*	Wt	Kg		1.32		3.17		4.05	
		Lbs		2.90		7.00		9.14	
Max Static Friction	Tf	N-m		0.127		0.346		0.450	
		Lb-Ft		0.0938		0.255		0.332	
Cogging Friction (Peak-to-Peak)	Tcog	N-m		0.071		0.216		0.285	
		Lb-Ft		0.0521		0.159		0.210	
Viscous Damping	Fi	N-m/ kRPM		4.24E-02		2.71E-01		4.06E-01	
		Lb-Ft / kRPM		3.12E-02		0.20		0.30	
Thermal Resistance*	TPR	°C / watt		1.55		1.20		1.14	
Number of Poles	P	-		12		12		12	

***Notes**

- 1) Continuous Stall Torque and Rated Power assume ambient temperature of 25°C
- 2) Winding temp = 155°C for Kt and Kb hot
- 3) Inertia and weight assume max thru-bore
- 4) TPR assumes motor is housed and mounted to a 7.0" x 7.5" x 0.375" heat sink or equivalent
- 5) Peak Torques limited by lead wire gauge

TBM 129 Series Performance Curves

TBM 129 PERFORMANCE CURVES

TBM(S)-12913-A
100 Vdc – 6 step

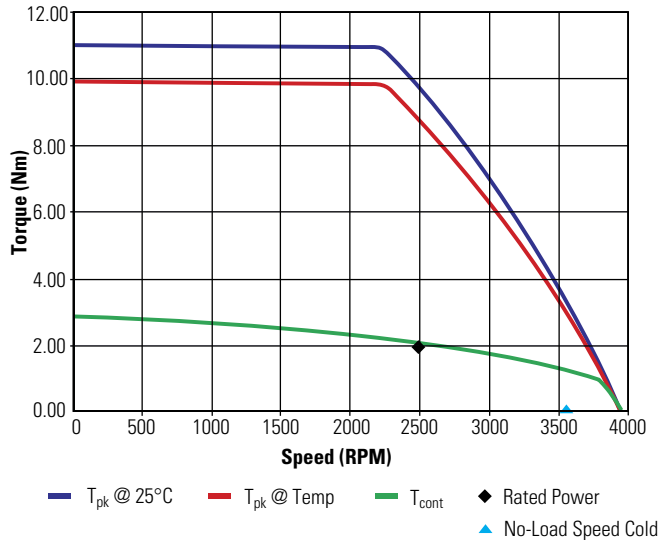

TBM(S)-12913-B
48 Vdc – 6 step

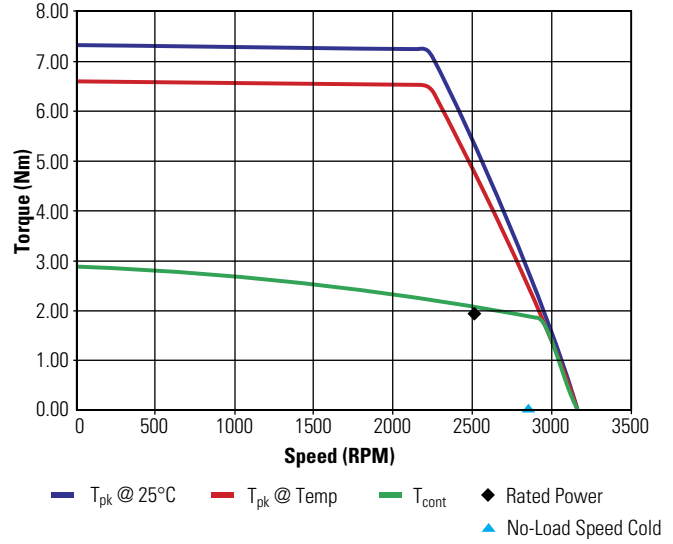

TBM(S)-12941-A
100 Vdc – 6 step

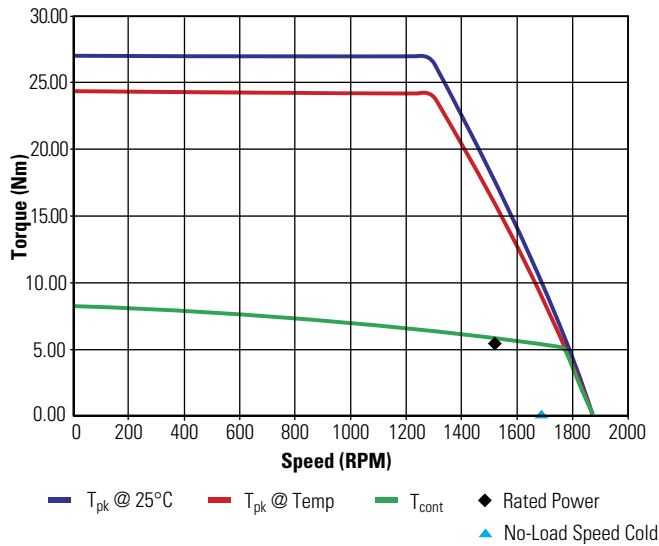

TBM(S)-12941-B
48 Vdc – 6 step

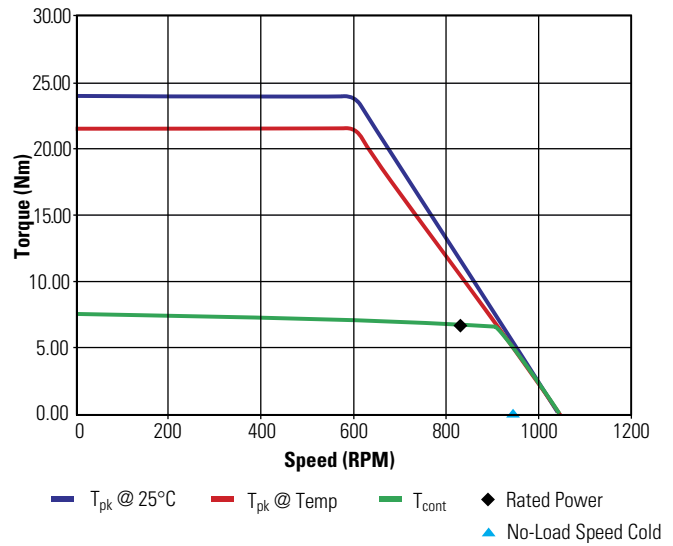

TBM(S)-12955-A
100 Vdc – 6 step

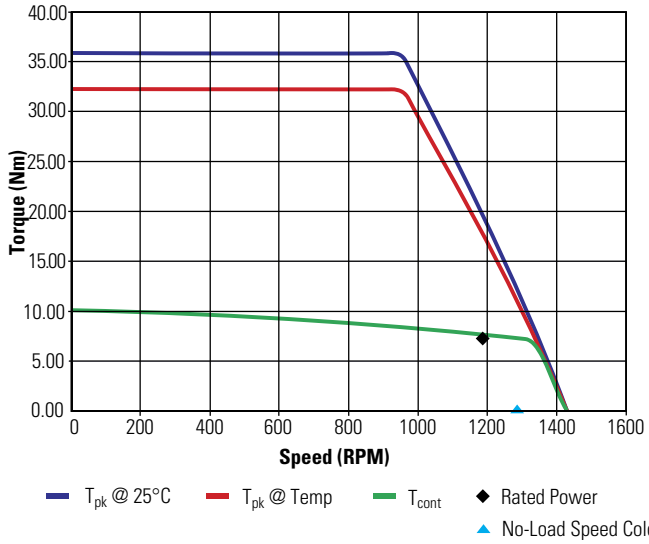

TBM(S)-12955-B
48 Vdc – 6 step

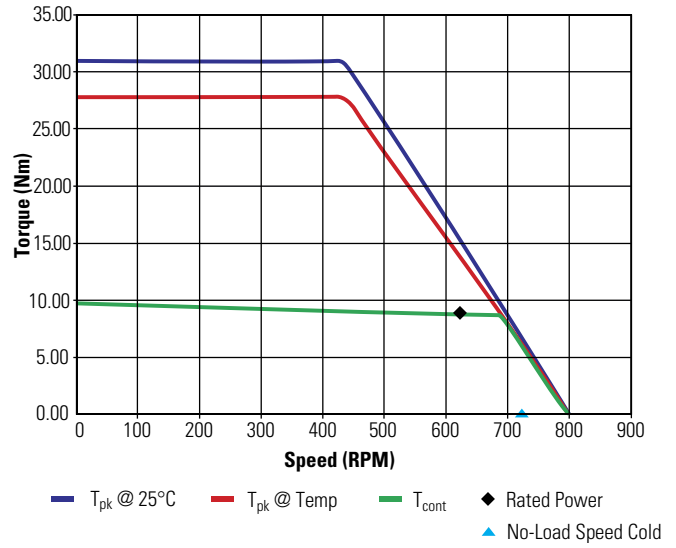

Notes:

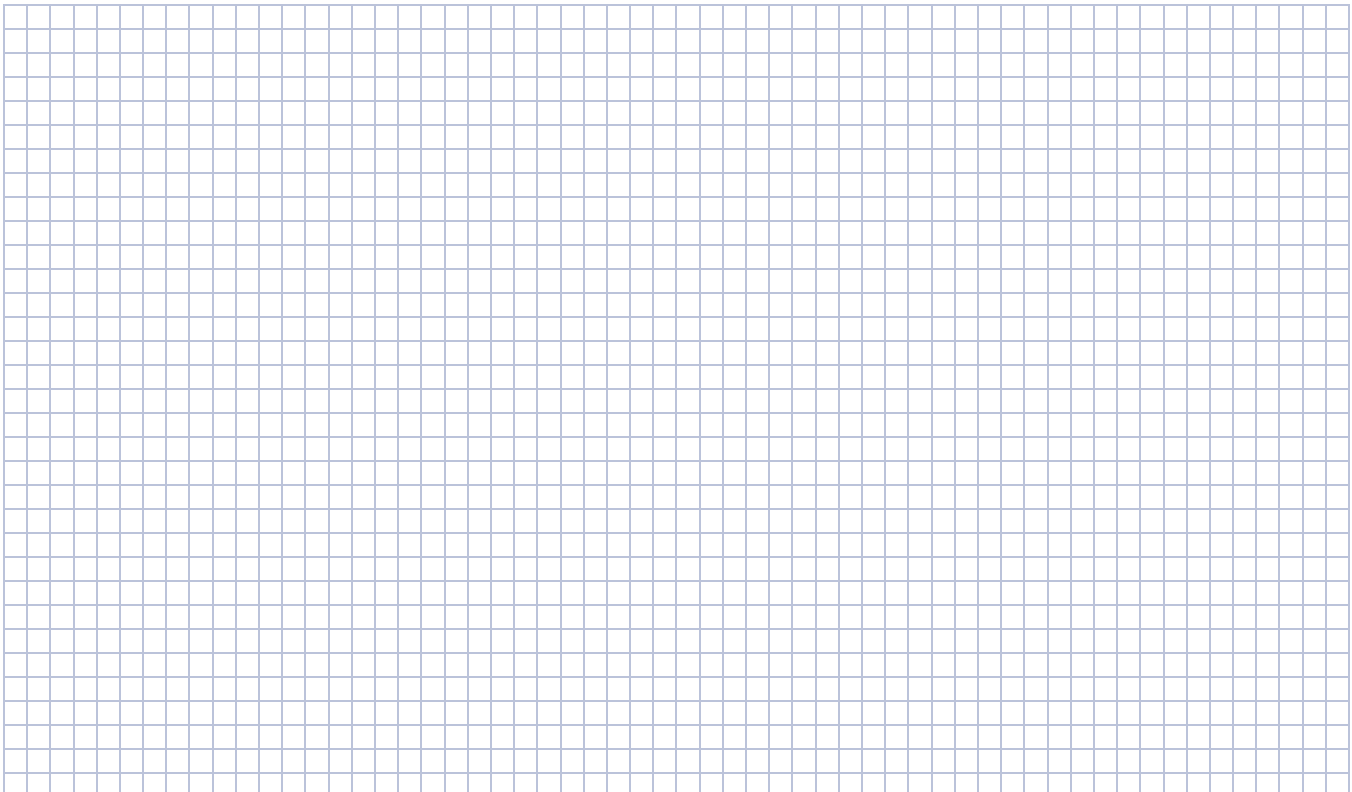

Connection Diagrams

Excitation Sequence Table

STEP	Power Connection		
	Phase "A" Red	Phase "B" White	Phase "C" Black
1	⊕	⊖	
2	⊕		⊖
3		⊕	⊖
4	⊖	⊕	
5	⊖		⊕
6		⊖	⊕

CW viewed from lead end

Hall Sensor Wiring Diagram

R = 1.5k Ohms (Customer Supplied)

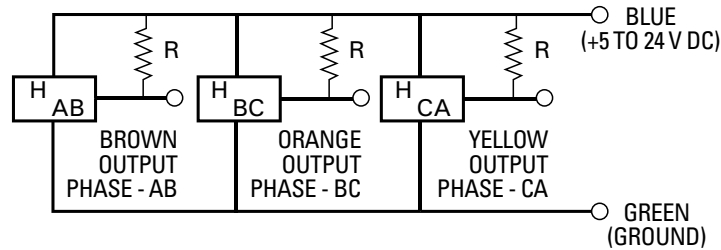

Hall Sensor Output

CW viewed from lead end

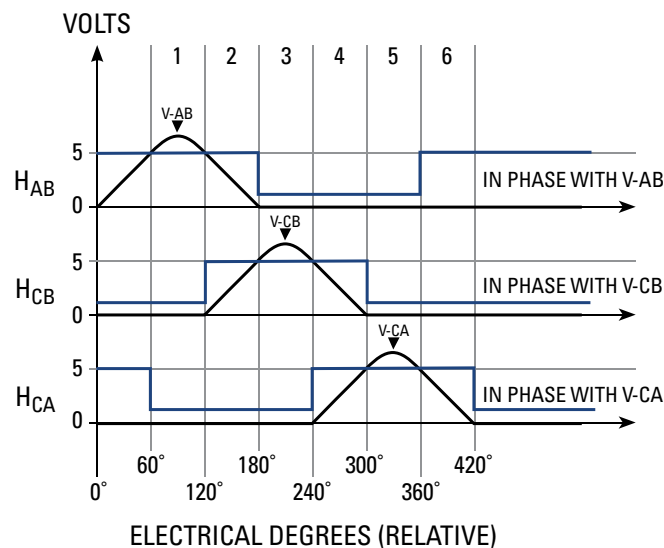

V-AB, V-BC, and V-CA is back EMF of motor phases AB, BC and CA respectively, aligned with sensor output as shown for CW rotation only

TBM Frameless Motor Nomenclature

TBM Frameless Motor

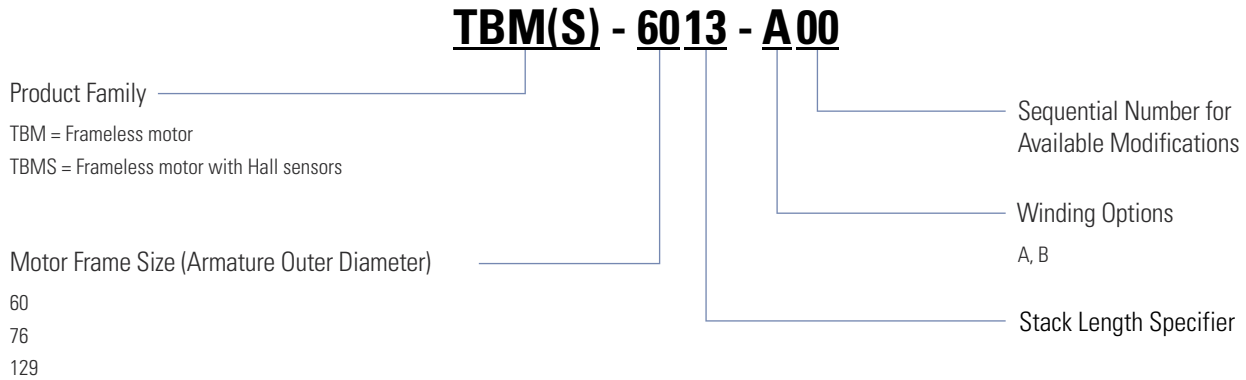

Available TBM(S) Modifications

Speed/Torque Changes

- Winding Gauges
- Stack Lengths

Generally Available Capability

#00 – #48 AWG (includes lead wire change)
Dependent on frame size

Installation Features

- Rotor Hub Geometry
Round, hollow, flanged, keyway, flat
Thru bores from 5 mm (0.20 in) up to max published (refer to outline drawing)
- Mounting
Bolt hole diameter and circumferential pattern (customer specified)
- Lead Length
400 mm (15.75 in) min (base model)
150 mm (5.90 in) to 1200 mm (47.0 in) (customer specified)
- Lead Colors
Red / White / Black (base model)
Other colors to be specified by customer
- Thermal Sensor
KTY or PTC type devices (embedded in motor slot only)