

# 103-H6701-0140

SANYO DENKI  
SANMOTION

## Dimensions (Unit:mm)

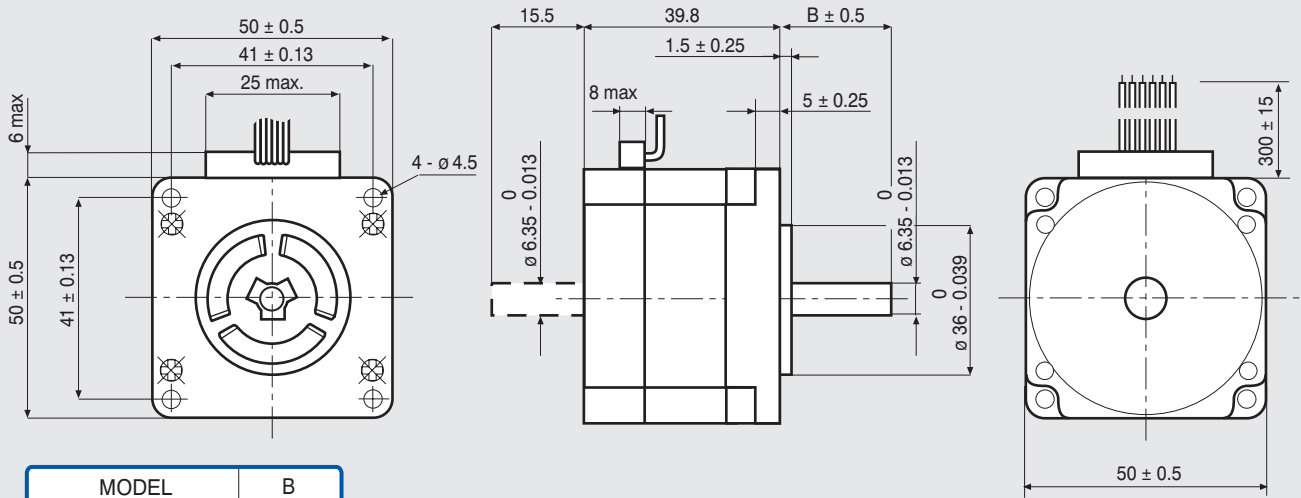

MODEL	B
103 - H6701 - 0140	20.6
103 - H6701 - 0113	28

## FEATURES

MODEL	103-H6701-0140 (103-H6701-0113)
BASIC STEP ANGLE	$1.8^\circ \pm 0.09^\circ$
BIPOLAR CURRENT (Amp)	0.7 <sup>(*)</sup>
UNIPOLAR CURRENT (Amp)	1.0
RESISTANCE (Ohm)	4.3
INDUCTANCE (mH)	6.8
BIPOLAR HOLDING TORQUE (Ncm)	38
UNIPOLAR HOLDING TORQUE (Ncm)	28
ROTOR INERTIA ( $\text{Kg} \cdot \text{m}^2 \times 10^{-7}$ )	57
THEORETICAL ACCELERATION ( $\text{rad} \times \text{sec}^{-2}$ )	66000
BACK E.M.F. (V/Krpm)	20
MASS (Kg)	0.35
LEADS CODE	IV

Codes between brackets refer to double shaft models.  
Le sigle fra parentesi si riferiscono ai modelli bialbero.

## TORQUE/SPEED CURVE

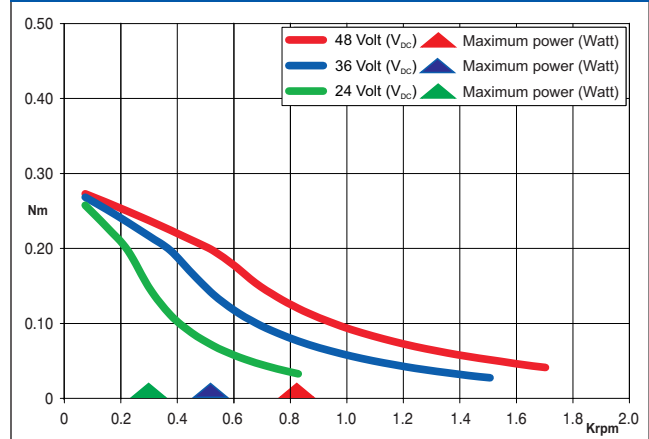

<sup>(\*)</sup>Bipolar series connection.  
<sup>(\*)</sup>Collegamento bipolare serie.

ORANGE / ARANCIO

WHITE / BIANCO

BLUE / BLU

RED / ROSSO

BLACK / NERO

YELLOW / GIALLO

IV

Suggested R.T.A. driver: BSD Series, CSD/A-CSD Series, NDC/A-NDC Series, HGD Series.

