

Dimensions (Unit:mm)

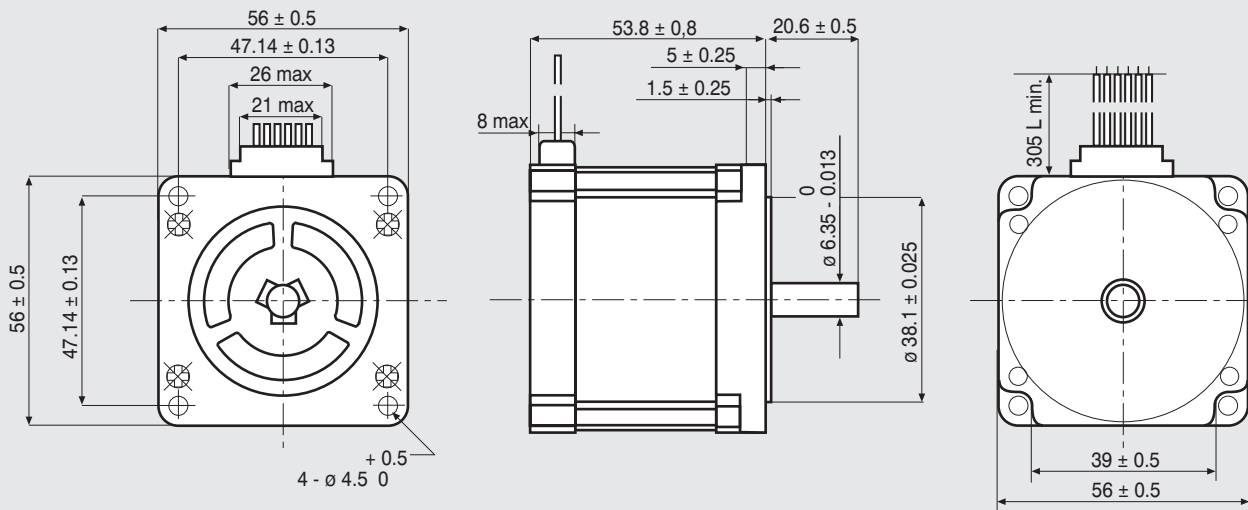

FEATURES

MODEL	103-H7123-0440	
BASIC STEP ANGLE	$1.8^\circ \pm 0.09^\circ$	
BIPOLAR CURRENT	(Amp)	1.5 ^(*)
UNIPOLAR CURRENT	(Amp)	2.0
RESISTANCE	(Ohm)	1.6
INDUCTANCE	(mH)	3.8
BIPOLAR HOLDING TORQUE	(Ncm)	110
UNIPOLAR HOLDING TORQUE	(Ncm)	85
ROTOR INERTIA	($\text{Kgm}^2 \times 10^{-7}$)	210
THEORETICAL ACCELERATION	($\text{rad} \times \text{sec}^{-2}$)	50000
BACK E.M.F.	(V/Krpm)	31
MASS	(Kg)	0.65
LEADS CODE	IV	

TORQUE/SPEED CURVE

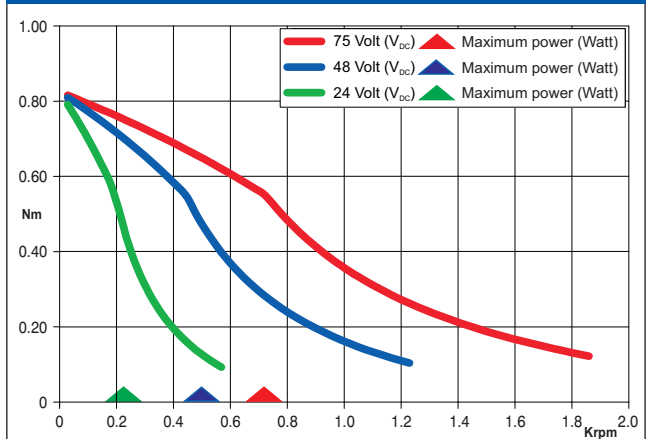

^(*)Bipolar series connection.
^(*)Collegamento bipolare serie.

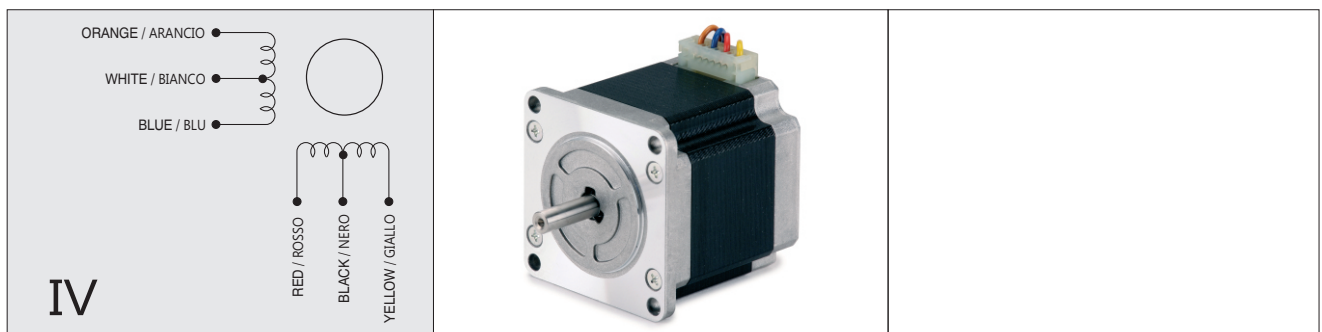

IV

Suggested R.T.A. driver: BSD Series, CSD/A-CSD Series, NDC/A-NDC Series, HGD Series.