

Dimensions (Unit:mm)

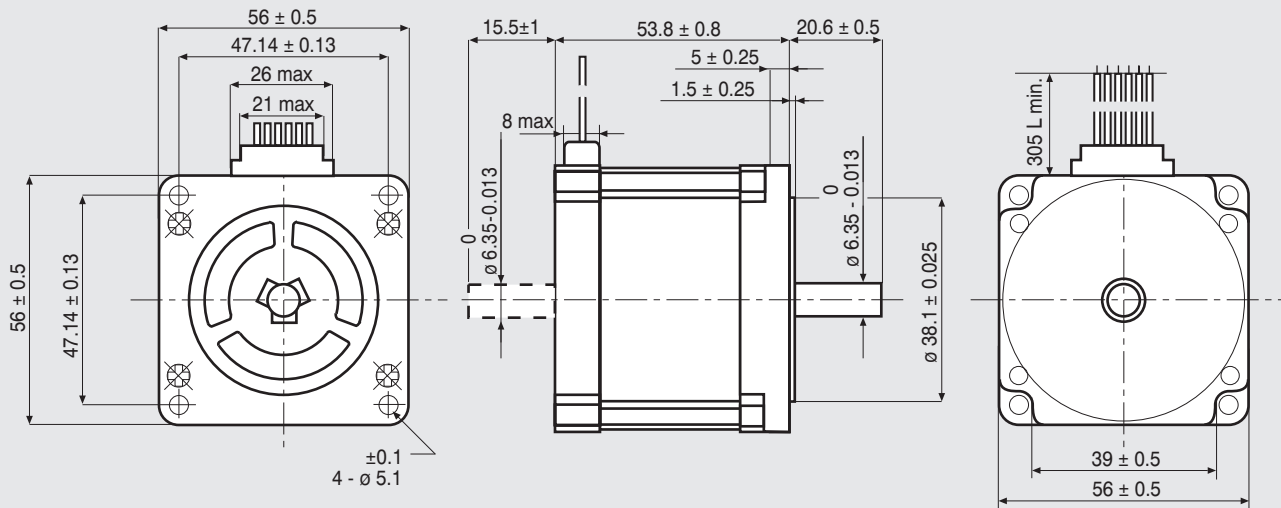

FEATURES

MODEL	103-H7123-1749 (103-H7123-1711)
BASIC STEP ANGLE	$1.8^\circ \pm 0.09^\circ$
BIPOLAR CURRENT (Amp)	4.0
UNIPOLAR CURRENT (Amp)	
RESISTANCE (Ohm)	0.41
INDUCTANCE (mH)	1.6
BIPOLAR HOLDING TORQUE (Ncm)	110
UNIPOLAR HOLDING TORQUE (Ncm)	
ROTOR INERTIA ($\text{Kgm}^2 \times 10^{-7}$)	210
THEORETICAL ACCELERATION ($\text{rad} \times \text{sec}^{-2}$)	50000
BACK E.M.F. (V/Krpm)	20
MASS (Kg)	0.65
LEADS CODE	V

Codes between brackets refer to double shaft models.
Le sigle fra parentesi si riferiscono ai modelli bialbero.

TORQUE/SPEED CURVE

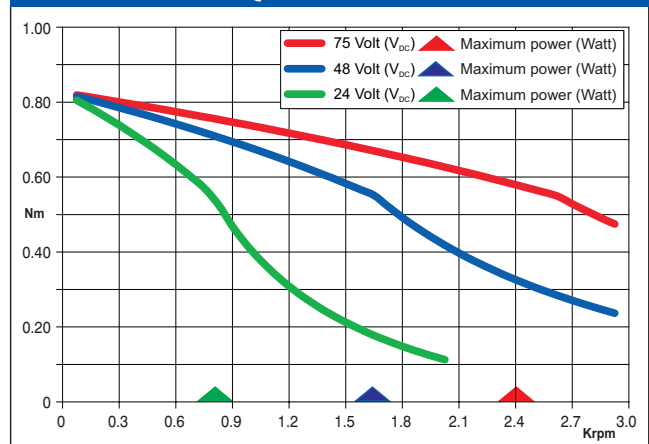

R.T.A. s.r.l. PAVIA (ITALY) SANYO DENKI CO., Ltd (JAPAN)

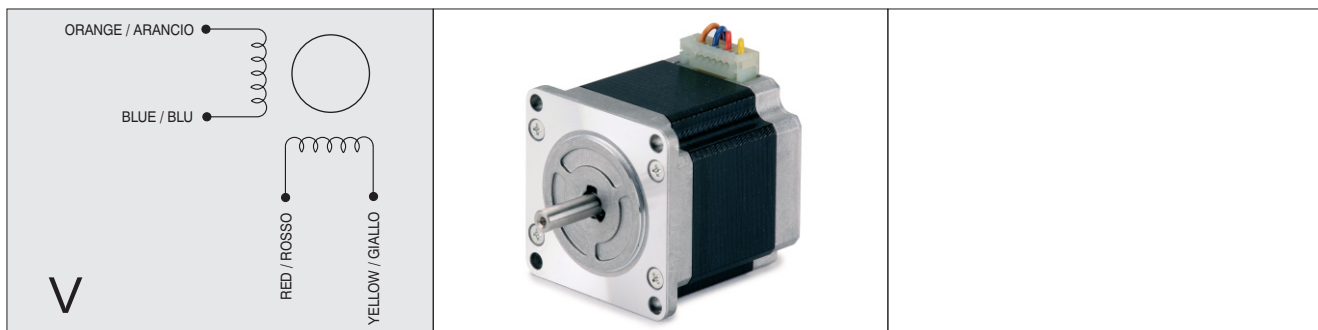

EMC - 10-14

Suggested R.T.A. driver: CSD/CSD J/A-CSD Series, NDC/A-NDC Series, ADW Series, HGD Series, PLUS Series.