

Dimensions (Unit:mm)

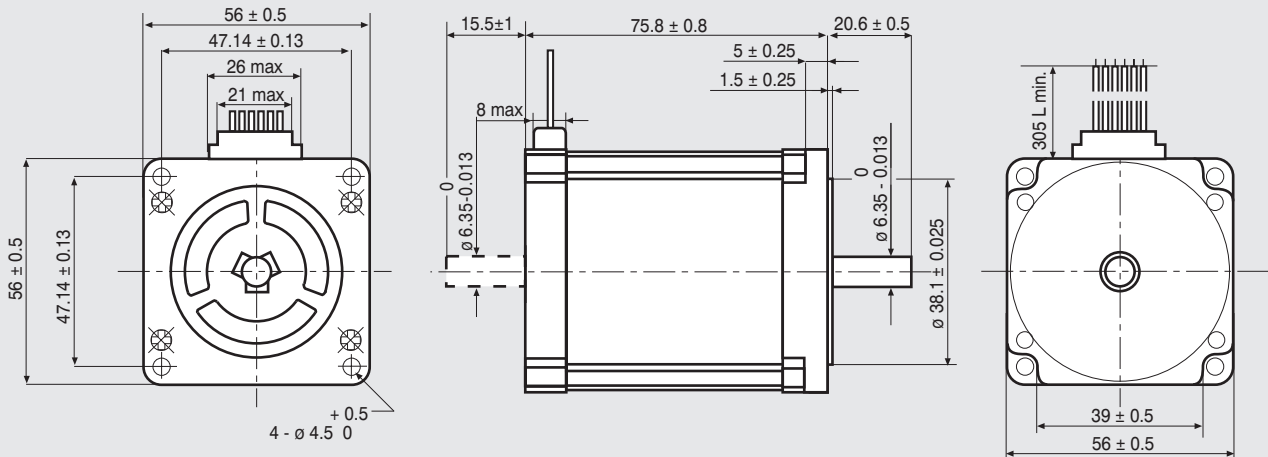

FEATURES

MODEL	103-H7126-1740 (103-H7126-1710)	
BASIC STEP ANGLE	$1.8^\circ \pm 0.09^\circ$	
BIPOLAR CURRENT	(Amp)	4.0
UNIPOLAR CURRENT	(Amp)	
RESISTANCE	(Ohm)	0.48
INDUCTANCE	(mH)	2.2
BIPOLAR HOLDING TORQUE	(Ncm)	165
UNIPOLAR HOLDING TORQUE	(Ncm)	
ROTOR INERTIA	(Kg $m^2 \times 10^{-7}$)	360
THEORETICAL ACCELERATION	(rad x sec. $^{-2}$)	45800
BACK E.M.F.	(V/Krpm)	31
MASS	(Kg)	1
LEADS CODE	V	

Codes between brackets refer to double shaft models.
Le sigle fra parentesi si riferiscono ai modelli bialbero.

TORQUE/SPEED CURVE

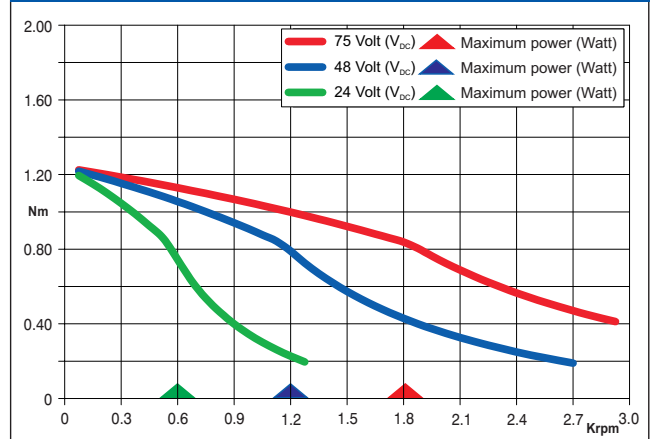

R.T.A. s.r.l. PAVIA (ITALY) SANYO DENKI CO., Ltd (JAPAN)



EMC - 10 - 14

Suggested R.T.A. driver: CSD/CSD J/A-CSD Series, NDC/A-NDC Series, ADW Series, HGD Series, PLUS Series.