

Hardware Version V1.1

HARDWARE MANUAL



TMCM-1180 PD86-1180

1-Axis Stepper
Controller / Driver
5.5A RMS/ 24 or 48V DC
USB, RS232, RS485, and CAN



stallGuard²



Table of Contents

2	Features.....	3
3	Order Codes	4
4	Mechanical and Electrical Interfacing	5
4.1	TMCM-1180 Dimensions and Mounting Holes	5
4.2	PD86-1180 Dimensions and Motor Specifications.....	6
4.2.1	Dimensions of PD86-3-1180.....	6
4.2.2	Motor Specifications of QSH8618-96-55-700.....	7
4.2.3	Torque Figure of QSH8618-96-55-700.....	8
4.3	Connectors of TMCM-1180	9
4.3.1	Power Connector	10
4.3.2	Serial Communication Connector	12
4.3.3	USB Connector.....	12
4.3.4	Output Connector	13
4.3.5	Input Connector.....	14
4.3.6	Step/Direction Connector	16
4.3.7	Encoder Connector	17
4.3.8	Motor Connector and Specifications.....	18
5	Jumpers	19
5.1	RS485 Bus Termination	19
5.2	CAN Bus Termination.....	19
6	Operational Ratings	20
7	Functional Description	21
7.1	System Architecture	21
7.1.1	Microcontroller	21
7.1.2	EEPROM.....	21
7.1.3	Motion Controller	21
7.1.4	Stepper Motor Driver	22
7.1.5	sensOstep Encoder.....	22
8	TMCM-1180 Operational Description	23
8.1	Calculation: Velocity and Acceleration vs. Microstep and Fullstep Frequency	23
9	TMCL	25
10	CANopen	25
11	Life Support Policy.....	26
12	Revision History	27
12.1	Document Revision	27
12.2	Hardware Revision	27
13	References.....	27

2 Features

The PD86-1180 is a full mechatronic solution with state of the arte feature set. It is highly integrated and offers a convenient handling. The PD86-1180 consists of a NEMA 34 (flange size 86mm) stepper motor, controller/driver electronics and integrated encoder.

The TMCM-1180 is an intelligent stepper motor controller/driver module featuring the new outstanding coolStep™ technology for sensorless load dependent current control. This allows energy efficient motor operation. With the advanced stallGuard2™ feature the load of the motor can be detected with high resolution. The module is designed to be mounted directly on an 86mm flange QMot stepper motor.

MAIN CHARACTERISTICS

Electrical data

- Supply voltage: +24V DC or +48V DC nominal
- Motor current: up to 5.5A RMS (programmable)

PANdrive motor

- Two phase bipolar stepper motor with up to 5.5A RMS nom. coil current
- Holding torque: 7Nm

Encoder

- Integrated sensOstep magnetic encoder (max. 256 increments per rotation) e.g. for step-loss detection under all operating conditions and positioning

Integrated motion controller

- Motion profile calculation in real-time (TMC428/429 motion controller)
- On the fly alteration of motor parameters (e.g. position, velocity, acceleration)
- High performance microcontroller for overall system control and serial communication protocol handling

Bipolar stepper motor driver

- Up to 256 microsteps per full step
- High-efficient operation, low power dissipation
- Dynamic current control
- Integrated protection
- stallGuard2 feature for stall detection
- coolStep feature for reduced power consumption and heat dissipation

Interfaces

- inputs for stop switches (left and right) and home switch
- general purpose inputs and 2 general purpose outputs
- USB, RS232, RS485 and CAN (2.0B up to 1Mbit/s) communication interfaces

Safety features

- Shutdown input. The driver will be disabled in hardware as long as this pin is left open or shorted to ground
- Separate supply voltage inputs for driver and digital logic – driver supply voltage may be switched off externally while supply for digital logic and therefore digital logic remains active

Software

- Available with TMCL™ or CANopen
- Standalone TMCL operation or remote controlled operation
- Program memory (non volatile) for up to 2048 TMCL commands
- PC-based application development software TMCL-IDE available for free
- CANopen: CiA 301 + CiA 402 (homing mode, profile position mode and velocity mode) supported

Please see separate TMCL and CANopen Firmware Manuals for additional information

3 Order Codes

Cables are not included. Add the appropriate cable loom to your order if required.

Order code	Description	Dimensions [mm ³]
TMC-1180 (-option)	TMC-1180 with coolStep, sensOstep	85.9 x 85.9 x 21.5
PD86-3-1180 (-option)	PD86-3-1180 with coolStep, sensOstep, 7.0 Nm	85.9 x 85.9 x 118.5

Table 3.1 PANdrive or module order codes

Option	Firmware
-TMCL	TMCL firmware
-CANopen	CANopen firmware

Table 3.2 Options for order codes

Component part	Description
TMC-1180-CABLE	Cable loom for module and PANdrive

Table 3.3 Order codes for component parts

4 Mechanical and Electrical Interfacing

4.1 TMCM-1180 Dimensions and Mounting Holes

The dimensions of the controller/driver board (TMCM-1180) are approx. 86mm x 86mm in order to fit to the back side of the 86mm stepper motor. The TMCM-1180 is 21.5mm high without matching connectors. There are four mounting holes for M4 screws.

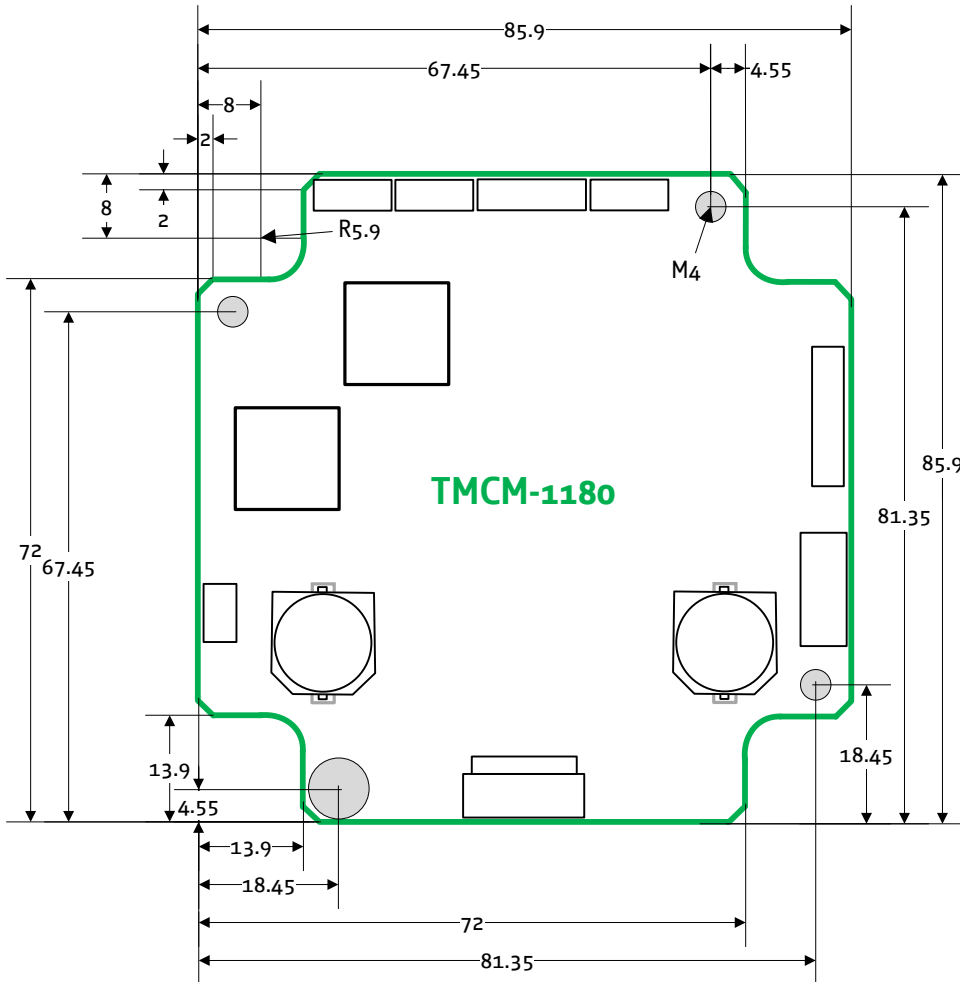

Figure 4.1 Dimensions of TMCM-1180 and mounting holes

4.2 PD86-1180 Dimensions and Motor Specifications

The PD86-1180 includes the TCMC-1180 stepper motor controller/driver electronic module, a magnetic encoder based on sensOstep technology and an 86mm flange size bipolar hybrid stepper motor.

4.2.1 Dimensions of PD86-3-1180

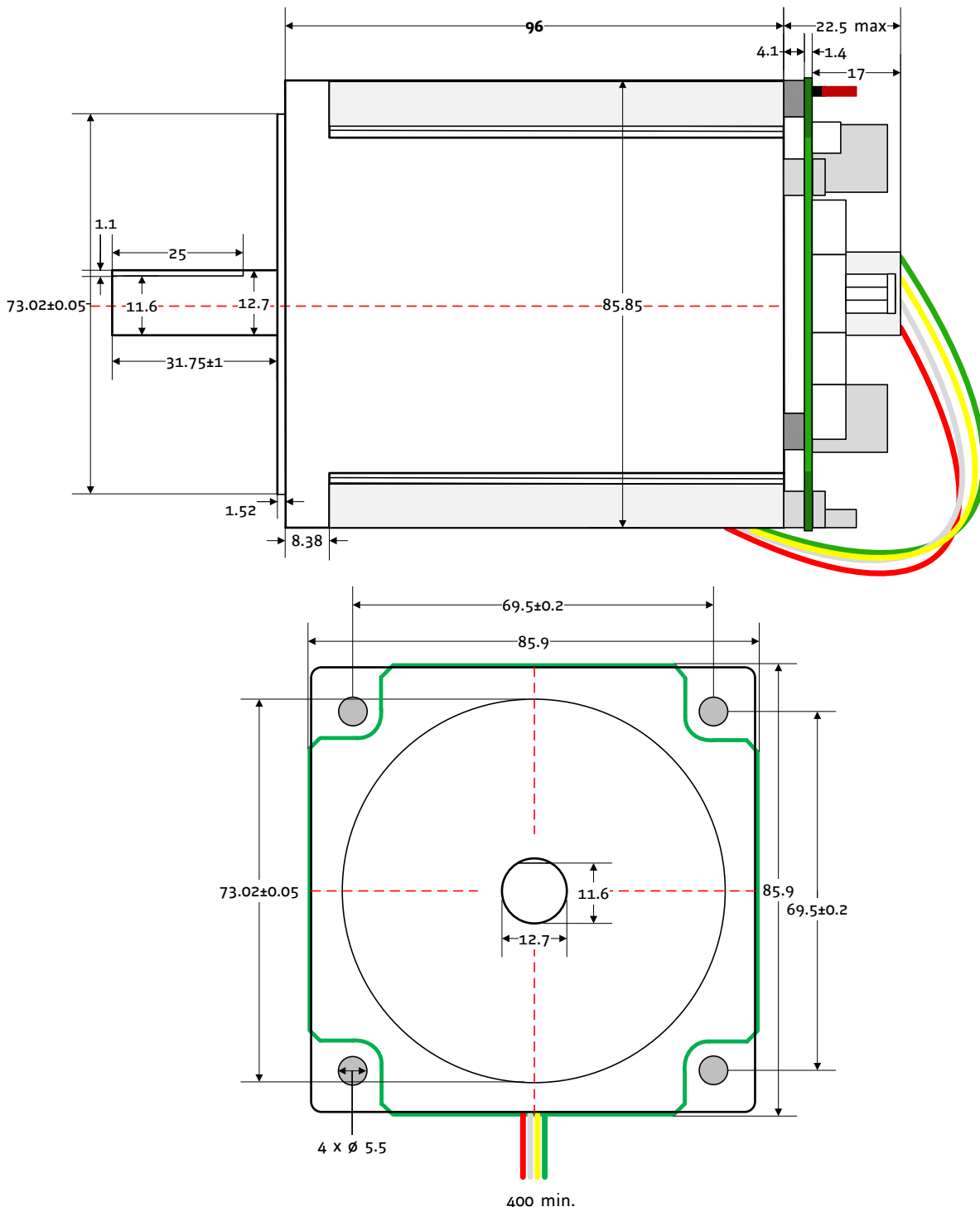

Figure 4.2 PD86-3-1180 dimensions

4.2.2 Motor Specifications of QSH8618-96-55-700

Specifications	Units	QSH8618-96-55-700
Wiring		
Rated Voltage	V	2.56
Rated Phase Current (nominal)	A	5.5
Phase Resistance at 20°C	Ω	0.45
Phase Inductance (typ.)	mH	4.5
Holding Torque (typ.)	Nm	7.0
Detent Torque	Nm	
Rotor Inertia	gcm ²	2700
Weight (Mass)	Kg	2.8
Insulation Class		B
Insulation Resistance	Ω	100M
Dialectic Strength (for one minute)	VAC	500
Connection Wires	N°	4
Max applicable Voltage	V	140
Step Angle	°	1.8
Step angle Accuracy	%	5
Flange Size (max.)	mm	85.85
Motor Length (max.)	mm	96
Axis Diameter	mm	12.7
Axis Length (visible part, typ.)	mm	31.75
Axis D-cut (1.1mm depth)	mm	25.0
Shaft Radial Play (450g load)	mm	0.02
Shaft Axial Play (450g load)	mm	0.08
Maximum Radial Force (20 mm from front flange)	N	220
Maximum Axial Force	N	60
Ambient Temperature	°C	-20... +50
Temp Rise (rated current, 2 phase on)	°C	max. 80

Table 4.1 Motor specifications of QSH8618-96-55-700

4.2.3 Torque Figure of QSH8618-96-55-700

The torque figure details the motor torque characteristics for full step operation in order to allow simple comparison. For full step operation there are always a number of resonance points (with less torque) which are not depicted. These will be minimized by microstep operation.

Testing conditions: 48V; 5,5A

— Full step

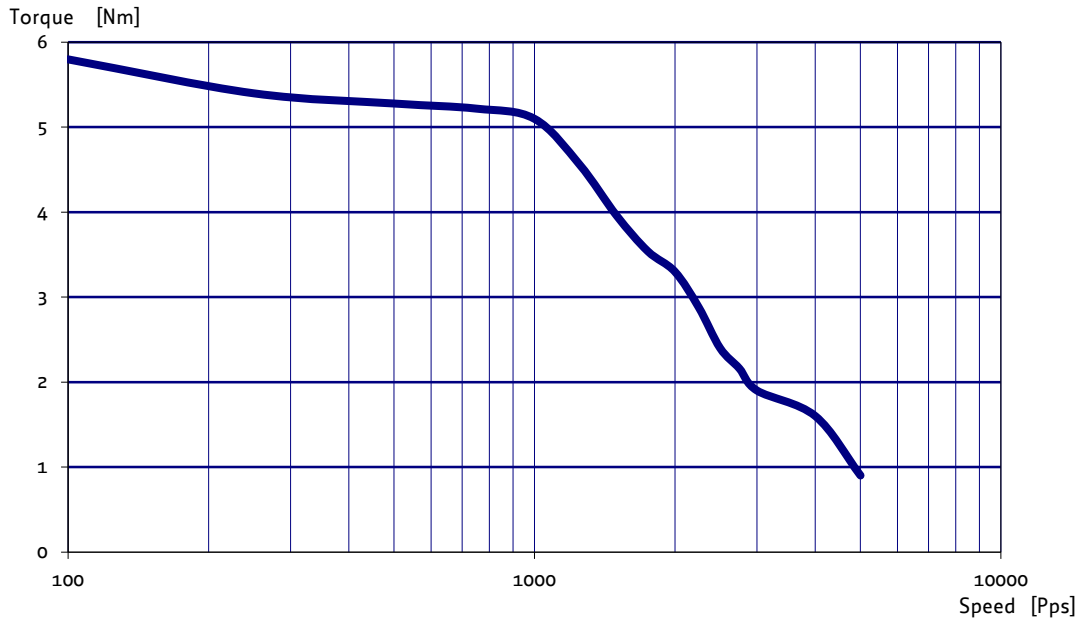

Figure 4.3 QSH8618-96-55-700 speed vs. torque characteristics

4.3 Connectors of TMCM-1180

The controller/driver board of the PD86-1180 offers eight connectors including the motor connector which is used internally for attaching the motor coils to the electronics. In addition to the power connector there are two connectors for serial communication (one for mini-USB and one for RS232/RS485/CAN) and two connectors for additional input and output signals. Further there is one connector for Step/Direction and another for the encoder.

The output connector offers two general purpose outputs, one power supply voltage output, and one hardware shutdown input. Leaving the shutdown input open or tying it to ground will disable the motor driver stage in hardware. For operation, this input should be tied to the supply voltage.

The input connector offers two inputs for stop switches (left and right), one home switch input, two general purpose inputs and one connection to the system or signal ground.

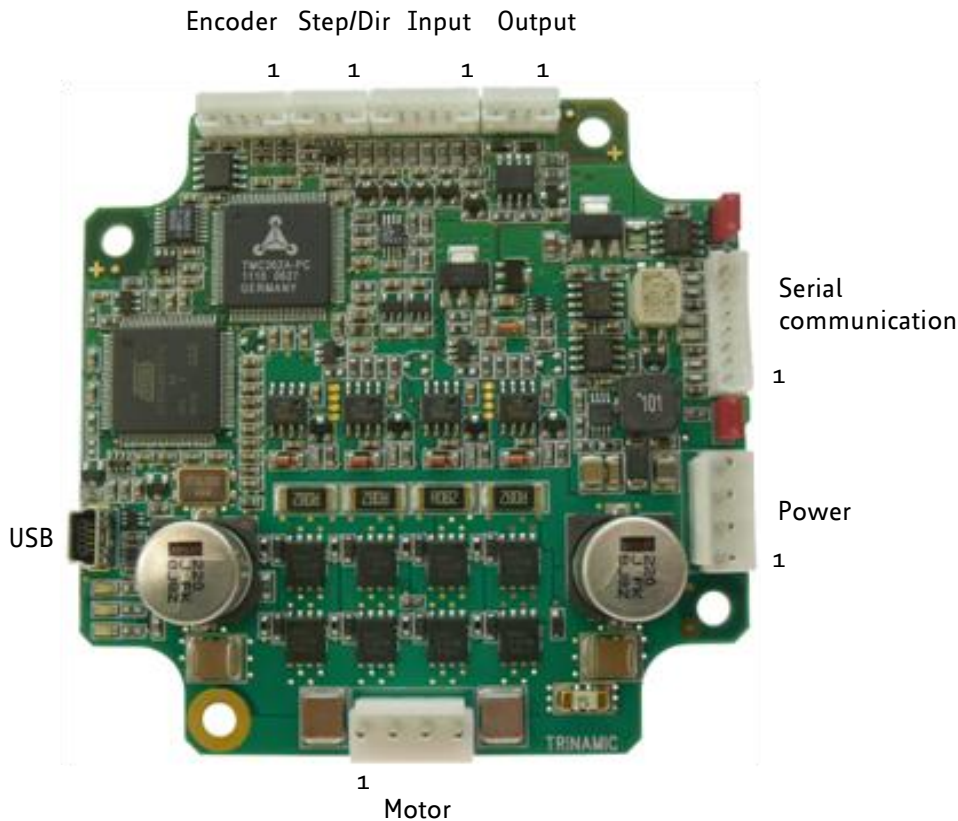

Figure 4.4 Overview connectors

Label	Connector type	Mating connector type
Power	JST B4P-VH JST VH series, 4 pins, 3.96mm pitch	Connector housing JST: VHR-4N Contacts JST: BVH-21T-P1.1
Motor	JST B4P-VH JST VH series, 4 pins, 3.96mm pitch	Connector housing JST: VHR-4N Contacts JST: BVH-21T-P1.1
Mini-USB	Molex 500075-1517 Mini USB Type B vertical receptacle	Any standard mini-USB plug
Serial communication	CI0108P1VK0-LF CVIlux CI01 series, 8 pins, 2mm pitch	Connector housing CVIlux: CI01085000-A Contacts CVIlux: CI01T011PE0-A <i>or</i> Connector housing JST: PHR-8 Contacts JST: SPH-002T-P0.5S Wire: 0.22mm ²

Label	Connector type	Mating connector type
Inputs	CI0106P1VK0-LF CVIlux CI01 series, 6 pins, 2mm pitch	Connector housing CVIlux: CI01065000-A Contacts CVIlux: CI01T011PE0-A <i>or</i> Connector housing JST: PHR-6 Contacts JST: SPH-002T-P0.5S Wire: 0.22mm ²
Outputs	CI0104P1VK0-LF CVIlux CI01 series, 4 pins, 2mm pitch	Connector housing CVIlux: CI01045000-A Contacts CVIlux: CI01T011PE0-A <i>or</i> Connector housing JST: PHR-4 Contacts JST: SPH-002T-P0.5S Wire: 0.22mm ²
Encoder	CI0105P1VK0-LF CVIlux CI01 series, 5 pins, 2mm pitch	Connector housing CVIlux: CI01055000-A Contacts CVIlux: CI01T011PE0-A <i>or</i> Connector housing JST: PHR-5 Contacts JST: SPH-002T-P0.5S Wire: 0.22mm ²
Step/Dir	CI0104P1VK0-LF CVIlux CI01 series, 4 pins, 2mm pitch	Connector housing CVIlux: CI01045000-A Contacts CVIlux: CI01T011PE0-A <i>or</i> Connector housing JST: PHR-4 Contacts JST: SPH-002T-P0.5S Wire: 0.22mm ²

Table 4.2 Connectors and mating connectors, contacts and applicable wire

4.3.1 Power Connector

This module offers separate power supply inputs for digital logic (pin 2) and driver/power stage (pin 1). Both supply inputs use common ground connections (pin 3 and 4). This way, power supply for the driver stage may be switched off while still maintaining position and status information when keeping digital logic supply active.

+U_{DRIVER} SUPPLY ONLY

In case power supply is provided to the power section only, an internal diode will distribute power to the logic section also. So, when separate power supplies are not required it is possible to just use pin 1 and 4 for powering the module.

	Pin	Label	Description
	1	+U _{Driver}	Module + driver stage power supply input (nom. +48V DC)
	2	+U _{Logic}	(Optional) separate digital logic power supply input (nom. +48V DC)
	3	GND	Module ground (power supply and signal ground)
	4	GND	Module ground (power supply and signal ground)





Table 4.3 Connector for power supply

To ensure reliable operation of the unit, the power supply has to have a sufficient output capacitor and the supply cables should have a low resistance, so that the chopper operation does not lead to an increased power supply ripple directly at the unit. Power supply ripple due to the chopper operation should be kept at a maximum of a few 100mV.

HINTS FOR POWER SUPPLY

- keep power supply cables as short as possible
- use large diameters for power supply cables

CAUTION!

	<p>Add external power supply capacitors!</p> <p>It is recommended to connect an electrolytic capacitor of significant size (e.g. 4700 μF / 63 V) to the power supply lines next to the PD-1180 especially if the distance to the power supply is large (i.e. more than 2-3m)! In larger systems a zener diode circuitry might be required in order to limit the maximum voltage when the motor is operated at high velocities.</p> <p>Rule of thumb for size of electrolytic capacitor: $c = 1000 \frac{\mu\text{F}}{\text{A}} \times I_{\text{SUPPLY}}$</p> <p>In addition to power stabilization (buffer) and filtering this added capacitor will also reduce any voltage spikes which might otherwise occur from a combination of high inductance power supply wires and the ceramic capacitors. In addition it will limit slew-rate of power supply voltage at the module. The low ESR of ceramic-only filter capacitors may cause stability problems with some switching power supplies.</p>
	<p>Do not connect or disconnect motor during operation!</p> <p>Motor cable and motor inductivity might lead to voltage spikes when the motor is disconnected / connected while energized. These voltage spikes might exceed voltage limits of the driver MOSFETs and might permanently damage them. Therefore, always disconnect power supply before connecting / disconnecting the motor.</p>
	<p>Keep the power supply voltage below the upper limit of 55V!</p> <p>Otherwise the driver electronics will seriously be damaged! Especially, when the selected operating voltage is near the upper limit a regulated power supply is highly recommended. Please see also chapter 6 (operating values).</p>
	<p>There is no reverse polarity protection!</p> <p>The module will short any reversed supply voltage due to internal diodes of the driver transistors.</p>

4.3.2 Serial Communication Connector

A 2mm pitch 8 pin connector is used for serial communication. With this connector the module supports RS232, RS485 and CAN communication.

	Pin	Label	Description
	1	RS232_TxD	RS232 transmit data
	2	RS232_RxD	RS232 receive data
	3	GND	Module ground (system and signal ground)
	4	CAN_H	CAN_H bus line (dominant high)
	5	CAN_L	CAN_L bus line (dominant low)
	6	GND	Module ground (system and signal ground)
	7	RS485+	RS485 non-inverted bus signal
8	RS485-	RS485 inverted bus signal	

Table 3.3 Connector for serial communication

4.3.3 USB Connector

A 5-pin mini-USB connector is available on board (might depend on assembly option).

	Pin	Label	Description
	1	VBUS	+5V power
	2	D-	Data -
	3	D+	Data +
	4	ID	Not connected
5	GND	ground	

Table 3.4 Mini USB connector

4.3.4 Output Connector

A 2mm pitch 4 pin connector is used for connecting the two general purpose outputs and the driver stage hardware shutdown input pin to the unit.

In order to enable the motor driver stage connect /Shutdown (pin 2) to +U_{Logic} (pin 1)!

Pin	Label	Description
1	+U _{Logic}	Module digital logic power supply – connected to pin 2 of power supply connector
2	/Shutdown	/Shutdown input – has to be connected to power supply (e.g. pin 1 of this connector) in order to enable driver. Connecting this input to ground or leaving it unconnected will disable driver stage
3	OUT_0	Open collector output with integrated freewheeling diode, +24V compatible
4	OUT_1	Open collector output with integrated freewheeling diode, +24V compatible

Table 4.4 Output / /Shutdown connector

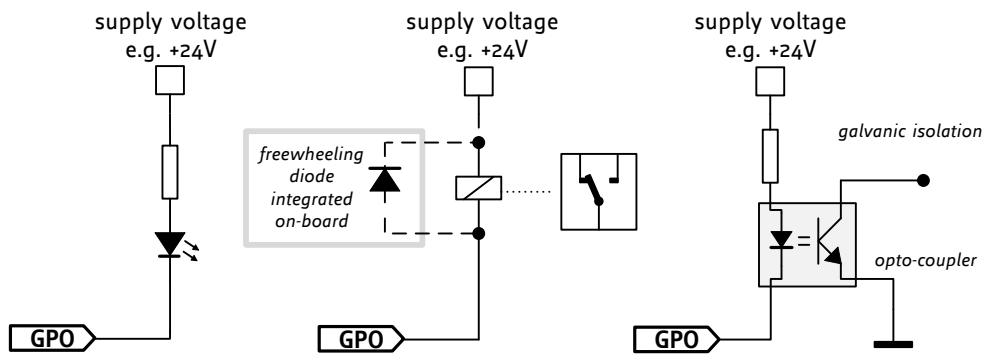

Figure 4.5 Possible circuits for GPO

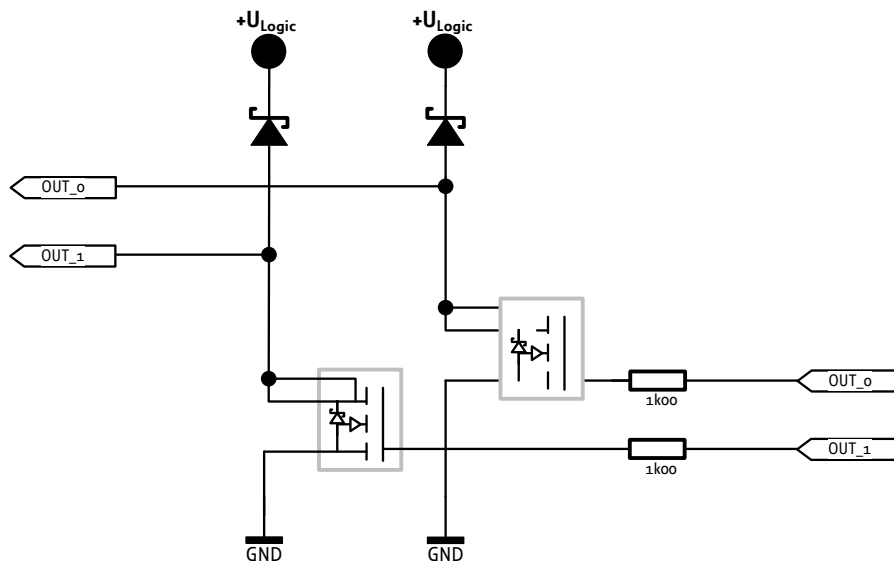

Figure 4.6 Internal circuit of the outputs

4.3.5 Input Connector

A 2mm pitch 6 pin connector is used for connecting general purpose inputs, home and stop switches to the unit.

Mating connector housing: PHR-6

Mating connector contacts: SPH-002T-P0.5S

	Pin	Label	Description
	1	IN_0	General purpose input, +24V compatible
	2	IN_1	General purpose input, +24V compatible
	3	STOP_L	Left stop switch input, +24V compatible, programmable internal pull-up (1k to +5V)
	4	STOP_R	Right stop switch input, +24V compatible, programmable internal pull-up (1k to +5V)
	5	HOME	Home switch input, +24V compatible, programmable internal pull-up (1k to +5V)
	6	GND	Module ground (system and signal ground)

Table 4.5 Input / Stop / Home switch connector

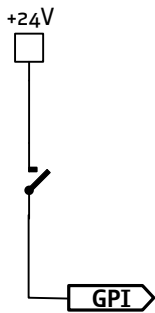

Figure 4.7 Possible circuit for GPI

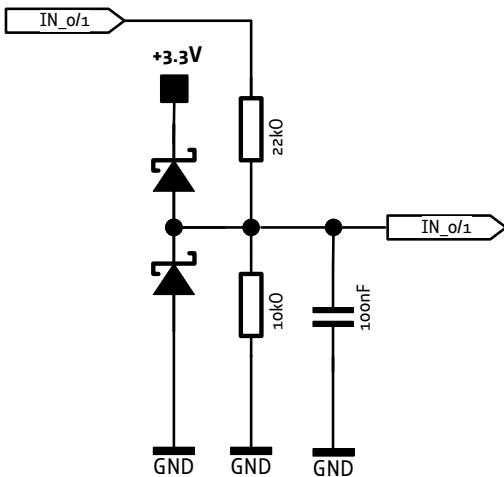

Figure 4.8 Internal circuit of the inputs

4.3.5.1 Left and Right Limit Switches

The TMCM-1180 can be configured so that a motor has a left and a right limit switch (Figure 4.9).

The motor stops when the traveler has reached one of the limit switches.

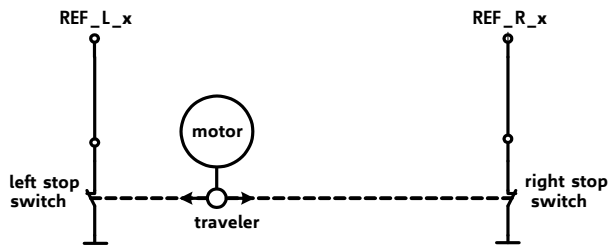

Figure 4.9 Left and right limit switches

4.3.5.2 Triple Switch Configuration

It is possible to program a tolerance range around the reference switch position. This is useful for a triple switch configuration, as outlined in Figure 4.10. In that configuration two switches are used as automatic stop switches, and one additional switch is used as the reference switch between the left stop switch and the right stop switch. The left stop switch and the reference switch are wired together. The center switch (travel switch) allows for a monitoring of the axis in order to detect a step loss.

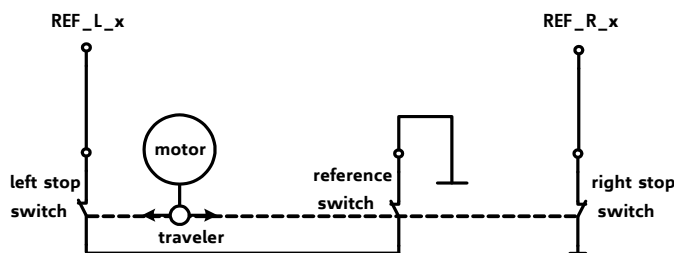

Figure 4.10 Limit switch and reference switch

4.3.5.3 One Limit Switch for Circular Systems

If a circular system is used (Figure 4.11), only one reference switch is necessary, because there are no end-points in such a system.

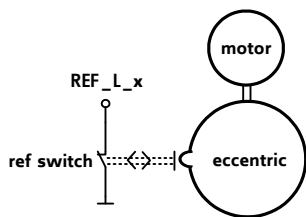

Figure 4.11 One reference switch

4.3.6 Step/Direction Connector

A 2mm pitch 4 pin connector is used for connecting the Step/Dir interface.

Pin	Label	Description
1	OC_COM	Common supply / opto-coupler (+5V .. +24V)
2	OC_EN	Enable signal
3	OC_STEP	Step signal
4	OC_DIR	Direction signal

Table 4.6 Step/Dir connector

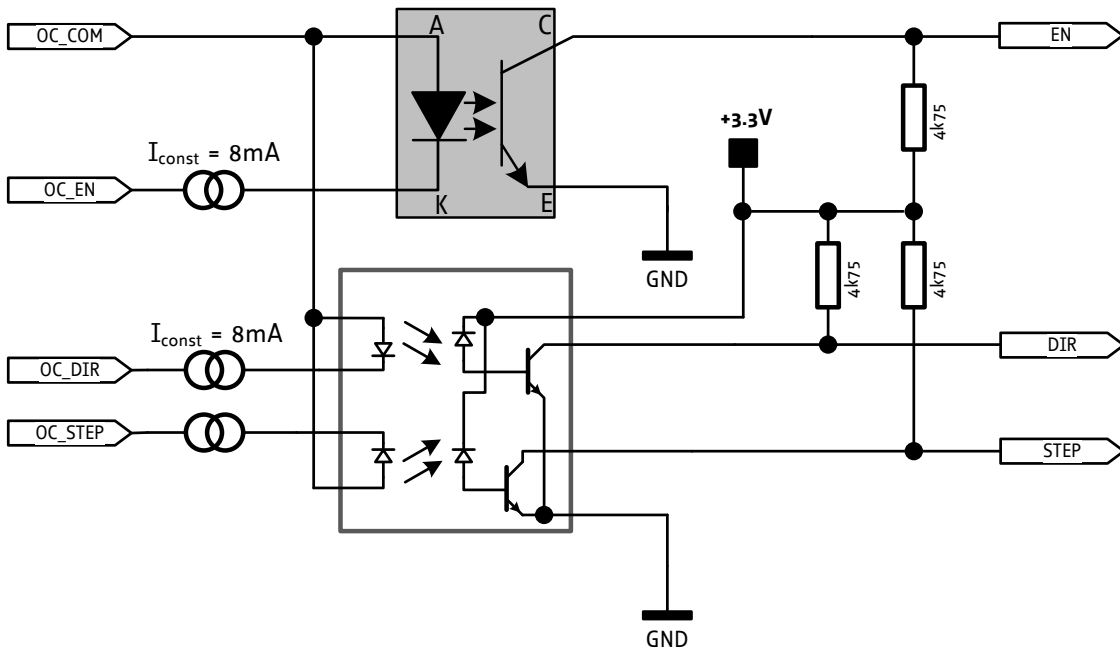

Figure 4.12 Internal circuit of the Step/Dir interface

4.3.7 Encoder Connector

A 2mm pitch 5 pin connector is used for connecting the Encoder.

Mating connector housing: PHR-5

Mating connector contacts: SPH-002T-P0.5S

Pin	Label	Description
1	ENC_A	Encoder A-channel
2	ENC_B	Encoder B-channel
3	ENC_N	Encoder N-channel
4	GND	Power and signal ground
5	+5V_output	+5V output for encoder power supply (max. 100mA)

Table 4.7 Encoder connector

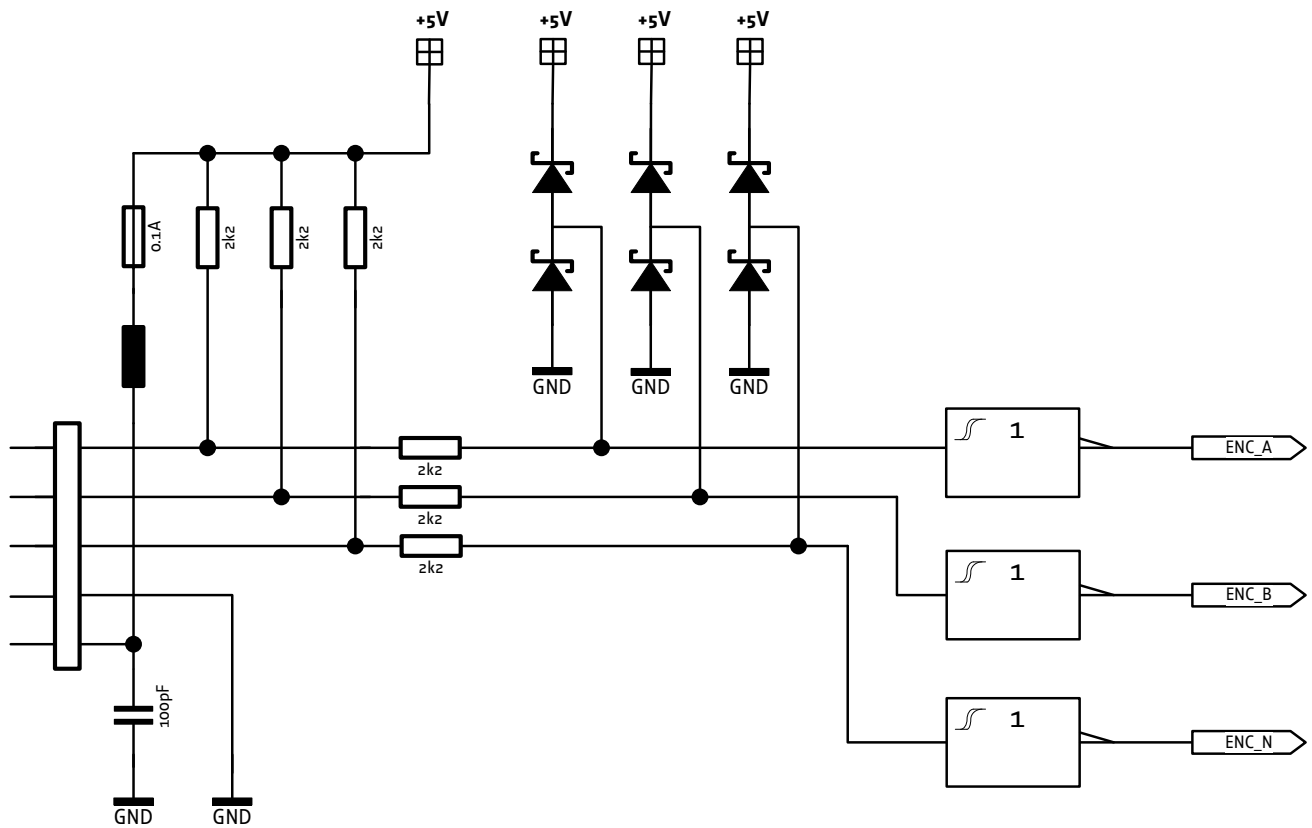

Figure 4.13 Internal circuit of encoder interface

Keep the electronics free of (metal) particles! The encoder uses a magnet at the end of the motor axis in order to monitor position. The magnet naturally attracts especially tiny metal particles. These particles might be held on the top side of the PCB and even worse – start moving in accordance with the rotating magnetic field as soon as the motor starts moving. This might lead to shorts of electronic contacts / wires on the board and totally erratic behavior of the module! Use compressed air for cleaning the module if necessary.

4.3.8 Motor Connector and Specifications

A 3.96mm pitch 4 pin connector is used for motor connection. Both motor coil windings (bipolar stepper motor) are connected to this connector.

Mating connector housing: VHR-4N

Mating connector contacts: BVH-21T-P1.1

Pin	Label	Description
1	OA1	Motor coil A
2	OA2	Motor coil A
3	OB1	Motor coil B
4	OB2	Motor coil B

Table 4.8 Connector for motor

5 Jumpers

Most settings of the board are done through the software. Nevertheless, a few jumpers are available for configuration.

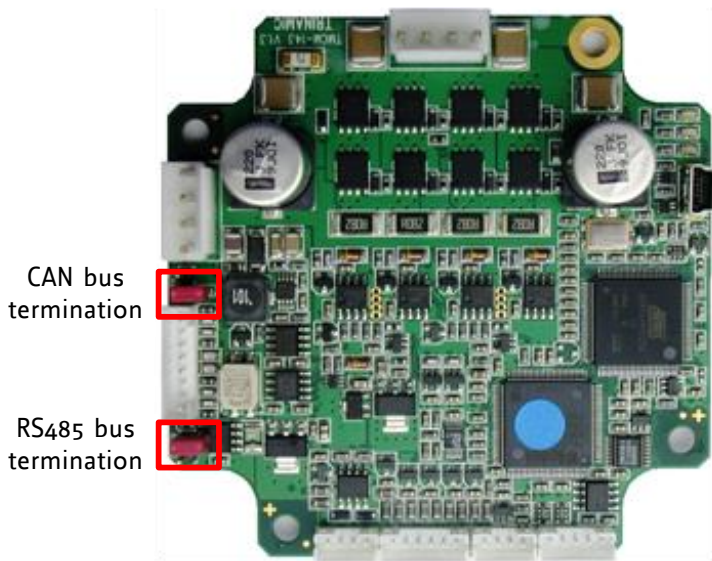

Figure 5.1 RS485 and CAN bus termination

5.1 RS485 Bus Termination

The board includes a 120 Ohm resistor for proper bus termination of the RS485 interface. When this jumper is closed, the resistor will be placed between the two differential bus lines RS485+ and RS485-.

5.2 CAN Bus Termination

The board includes a 120 Ohm resistor for proper bus termination of the CAN interface. When this jumper is closed, the resistor will be placed between the two differential bus lines CAN_H and CAN_L.

6 Operational Ratings

The operational ratings shown below should be used as design values. In no case should the maximum values been exceeded during operation.

Symbol	Parameter	Min	Typ	Max	Unit
$+U_{\text{Driver}} / +U_{\text{Logic}}$	Power supply voltage for operation	18	24 or 48	55	V DC
$I_{\text{COIL_peak}}$	Motor coil current for sine wave peak (chopper regulated, adjustable via software)	0		7.8	A
$I_{\text{COIL_RMS}}$	Continuous motor current (RMS)	0		5.5	A
I_{SUPPLY}	Power supply current		$\ll I_{\text{COIL}}$	$1.4 * I_{\text{COIL}}$	A
T_{ENV}	Environment temperature at rated current (no forced cooling required)	-20		+50 ^{*)}	°C

Table 6.1 General operational ratings of the module

*) The controller driver electronics has been tested inside a climate chamber running at full current (5.5A RMS) for 30min without air convection at 50°C environmental temperature.

The motor might heat up well above 50°C when running at full current without proper cooling. This might substantially increase the environmental temperature for the electronics. When using the *coolStep operation mode*, the actual current might be substantially less than programmed max. current producing and temperature.

7 Functional Description

In figure 7.1 the main parts of the PD86-1180 are shown. The PANdrive mainly consists of the μC (connected to the EEPROM TMCL memory), the TMC428/429 motion controller, the TMC262A-PC power driver with its energy efficient coolStep feature, the external MOSFET driver stage, the QSH8618 stepper motor, and the integrated sensOstep encoder. Alternatively it is possible to connect an external encoder. Nominal supply voltages are 24VDC or 48VDC.

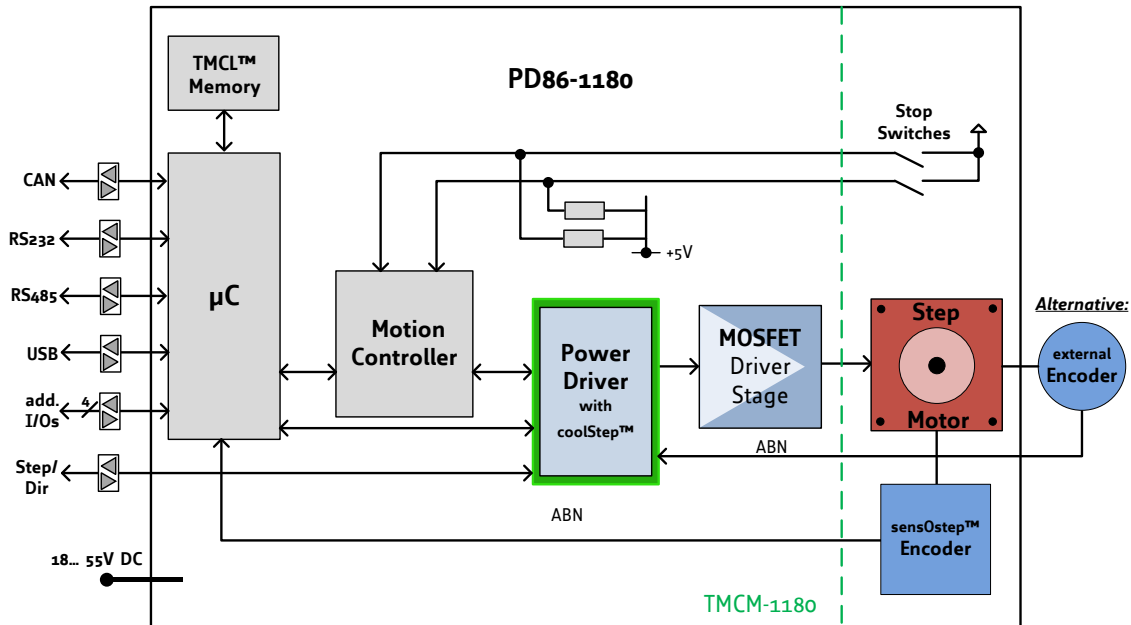

Figure 7.1 Main parts of the PD86-1180

7.1 System Architecture

The TMCM-1180 integrates a microcontroller with the TMCL (Trinamic Motion Control Language) operating system. The motion control real-time tasks are realized by the TMC428/429.

7.1.1 Microcontroller

On this module, the Atmel AT91SAM7X256 is used to run the TMCL operating system and to control the TMC428/429. The CPU has 256KB flash memory and a 64KB RAM. The microcontroller runs the TMCL (Trinamic Motion Control Language) operating system which makes it possible to execute TMCL commands that are sent to the module from the host via the RS232, RS485, USB, or CAN interface. The microcontroller interprets the TMCL commands and controls the TMC428/429 which executes the motion commands. In addition it is connected with the encoder interface and processes the inputs.

The flash ROM of the microcontroller holds the TMCL operating system. The TMCL operating system can be updated via the RS232 interface or via the CAN interface. Use the TMCL-IDE to do this.

7.1.2 EEPROM

To store TMCL programs for stand-alone operation the TMCM-1180 module is equipped with a 16kByte EEPROM attached to the microcontroller. The EEPROM can store TMCL programs consisting of up to 2048 TMCL commands. The EEPROM is also used to store configuration data.

7.1.3 Motion Controller

The TMC428/429 is a high-performance stepper motor control IC and can control up to three 2-phase-stepper-motors. Motion parameters like speed or acceleration are sent to the TMC428/429 via SPI by the microcontroller. Calculation of ramps and speed profiles are done internally by hardware based on the target motion parameters.

7.1.4 Stepper Motor Driver

The TMC262A-PC is an energy efficient high current high precision microstepping driver IC for bipolar stepper motors. This driver on the TCM-1180 module is a special version of the TMC262 power driver for PANdrives with QSH8618 motors.

Its unique high resolution sensorless load detection stallGuard2 is used for a special integrated load dependent current control feature called coolStep. The ability to read out the load and detect an overload makes the TMC262 an optimum choice for drives where a high reliability is desired. The TMC262 can be driven with step/direction signals as well as by serial SPI™.

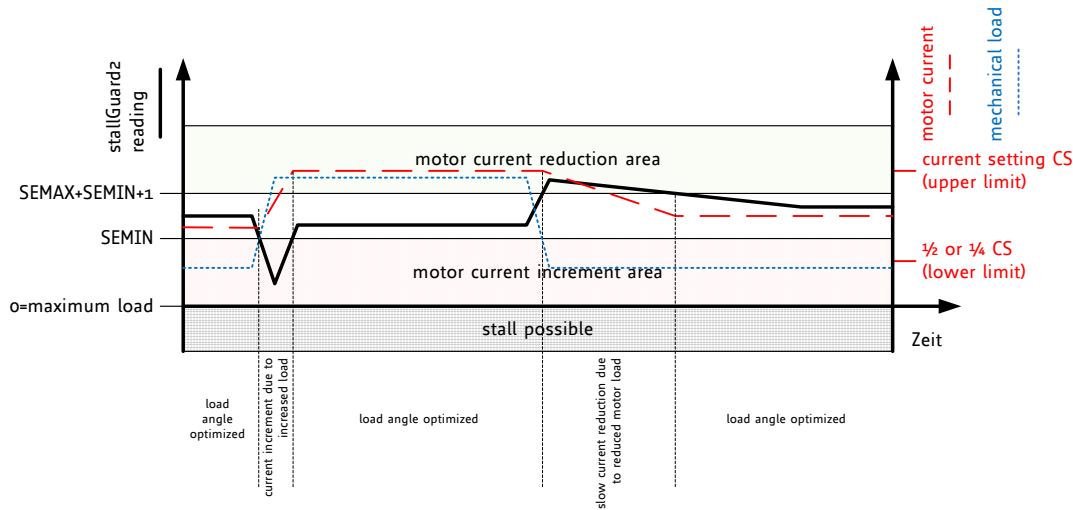

Figure 7.2 Motor current control via coolStep adapts motor current to motor load



coolStep™

The coolStep current regulator allows to control the reaction of the driver to increasing or decreasing load. The internal regulator uses two thresholds to determine the minimum and the maximum load angle for optimum motor operation. The current increment speed and the current decrement speed can be adapted to the application. Additionally, the lower current limit can be set in relation to the upper current limit set by the current scale parameter CS.

7.1.5 sensOstep Encoder

The sensOstep encoder used in this unit is based on a magnetic angular position encoder system with low resolution. It consists of a small magnet positioned at the back end of a stepper motor axis and a Hall-sensor IC with integrated digital signal processing (e.g. for automatic gain control, temperature compensation etc.) placed above the magnet on the back side of a motor mounted printed circuit board. The encoder offers a resolutions of 8 bit (256 steps) per revolution which is completely sufficient for detecting step losses with a standard 1.8° stepper motors.

8 TCM-1180 Operational Description

8.1 Calculation: Velocity and Acceleration vs. Microstep and Fullstep Frequency

The values of the parameters sent to the TMC428/429 do not have typical motor values like rotations per second as velocity. But these values can be calculated from the TMC428/429-parameters as shown in this section.

PARAMETERS FOR THE TMC428/429

Signal	Description	Range
f _{CLK}	clock-frequency	16 MHz
velocity	-	0... 2047
a_max	maximum acceleration	0... 2047
pulse_div	Divider for the velocity. The higher the value is, the less is the maximum velocity default value = 0	0... 13
ramp_div	Divider for the acceleration. The higher the value is, the less is the maximum acceleration default value = 0	0... 13
Usrs	microstep-resolution (microsteps per fullstep = 2 ^{usrs})	0... 7

Table 8.1 TMC428/429 velocity parameters

The **microstep-frequency** of the stepper motor is calculated with

$$usf[Hz] = \frac{f_{CLK}[Hz] \cdot velocity}{2^{pulse_div} \cdot 2048 \cdot 32} \quad \text{with usf: microstep-frequency}$$

To calculate the **fullstep-frequency** from the microstep-frequency, the microstep-frequency must be divided by the number of microsteps per fullstep.

$$fsf[Hz] = \frac{usf[Hz]}{2^{usrs}} \quad \text{with fsf: fullstep-frequency}$$

The change in the pulse rate per time unit (pulse frequency change per second – the **acceleration a**) is given by

$$a = \frac{f_{CLK}^2 \cdot a_{max}}{2^{pulse_div+ramp_div+29}}$$

This results in acceleration in fullsteps of:

$$af = \frac{a}{2^{usrs}} \quad \text{with af: acceleration in fullsteps}$$

EXAMPLE

Signal	value
f _{CLK}	16 MHz
velocity	1000
a _{max}	1000
pulse_div	1
ramp_div	1
usrs	6

$$msf = \frac{16 \text{ MHz} \cdot 1000}{2^1 \cdot 2048 \cdot 32} = \underline{\underline{122070.31 \text{ Hz}}}$$

$$fsf[\text{Hz}] = \frac{122070.31}{2^6} = \underline{\underline{1907.34 \text{ Hz}}}$$

$$a = \frac{(16 \text{ MHz})^2 \cdot 1000}{2^{1+1+29}} = \underline{\underline{119.21 \frac{\text{MHz}}{\text{s}}}}$$

$$af = \frac{119.21 \frac{\text{MHz}}{\text{s}}}{2^6} = \underline{\underline{1.863 \frac{\text{MHz}}{\text{s}}}}$$

Calculation of the number of rotations:

A stepper motor has e.g. 72 fullsteps per rotation.

$$RPS = \frac{fsf}{\text{fullsteps per rotation}} = \frac{1907.34}{72} = 26.49$$

$$RPM = \frac{fsf \cdot 60}{\text{fullsteps per rotation}} = \frac{1907.34 \cdot 60}{72} = 1589.46$$

9 TMCL

TMCL, the TRINAMIC Motion Control Language, is described in separate documentations, which refer to the specific products (e.g. TMCM-1180 TMCL Firmware Manual). The manuals are provided on www.trinamic.com. Please refer to these source for updated data sheets and application notes.

10 CANopen

The TMCM-1180 module should also be used with the CANopen protocol in future versions. For this purpose, a special CANopen firmware is under development. Please contact TRINAMIC if you are interested in this option.

11 Life Support Policy

TRINAMIC Motion Control GmbH & Co. KG does not authorize or warrant any of its products for use in life support systems, without the specific written consent of TRINAMIC Motion Control GmbH & Co. KG.

Life support systems are equipment intended to support or sustain life, and whose failure to perform, when properly used in accordance with instructions provided, can be reasonably expected to result in personal injury or death.

© TRINAMIC Motion Control GmbH & Co. KG 2013

Information given in this data sheet is believed to be accurate and reliable. However neither responsibility is assumed for the consequences of its use nor for any infringement of patents or other rights of third parties, which may result from its use.

Specifications are subject to change without notice.

All trademarks used are property of their respective owners.



12 Revision History

12.1 Document Revision

Version	Date	Author GE – Göran Eggers SD – Sonja Dwersteg	Description
0.90	2009-AUG-04	GE	Initial version
0.91	2009-NOV-11	GE	New hardware included
1.00	2010-JUN-28	SD	New engineering detail drawings. Functional and operational descriptions added.
1.01	2011-MAR-21	SD	New front page, minor changes
1.02	2011-JUN-08	SD	Minor changes
1.03	2011-DEC-02	SD	Order codes new, minor changes
1.04	2012-DEC-15	SD	Changes related to the design.
1.05	2013-JUL-26	SD	Connector description updated. Chapter 4.3.1 updated.

Table 12.1 Document revision

12.2 Hardware Revision

Version	Date	Description
1.00	2010-OCT-29	Pre-series version
1.10	2011-MAR-03	Series version

Table 12.2 Hardware revision

13 References

[TMCM-1180 / PD86-1180 TMCL]
[TMCL-IDE]
[QSH8618]

TMCM-1180 and PD86-1180 TMCL Firmware Manual
TMCL-IDE User Manual
QSH8618 Manual

Please refer to www.trinamic.com.