



Nippon Pulse
Your Partner in Motion Control

PMX-4ET-SA

**Advanced 4-Axis Motion Controller
with Ethernet Communication**



Specifications

- 4 Axis Advanced Motion Controller
- 10 Mbps Ethernet Communication
- 6M maximum pulse rate output
- Trapezoidal or s-curve acceleration
- On-the-fly speed change
- Continuous linear coordinated buffered XYZ move
- XYZU linear coordinated motion
- XY circular and arc coordinated motion
- Homing using Home and/or Index encoder channel
- Pulse/Dir/Enable open collector outputs per axis
- Opto-isolated +Limit, -Limit, Home, and Alarm inputs per axis
- Single-ended or differential quadrature encoder inputs per axis
- Opto-isolated Digital Inputs (8)
- Opto-isolated Digital Outputs (8)
- High speed position capture inputs and sync outputs
- Built-in StepNLoop closed loop control algorithm
- BASIC-like standalone programming language
- Multi-task programming support

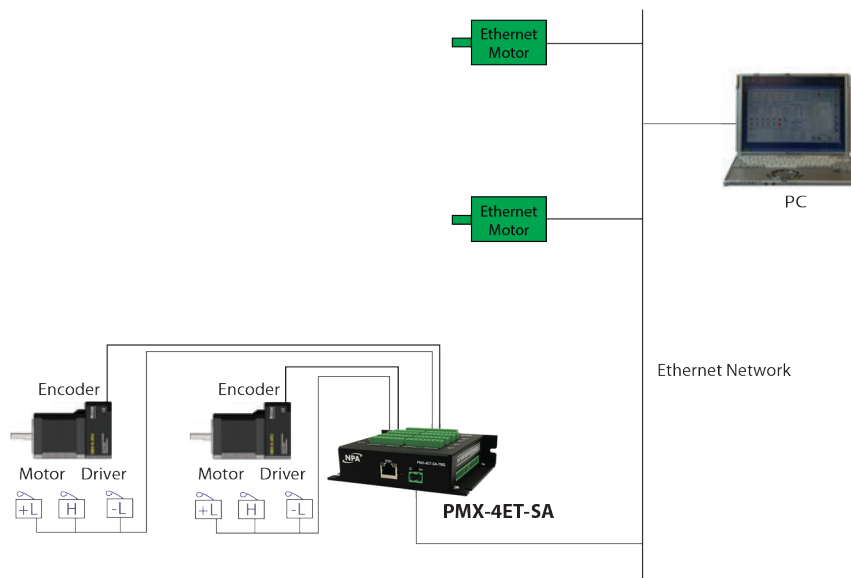

PMX-4ET-SA

Advanced 4-Axis Motion Controller with Ethernet Communication

Electrical Interface

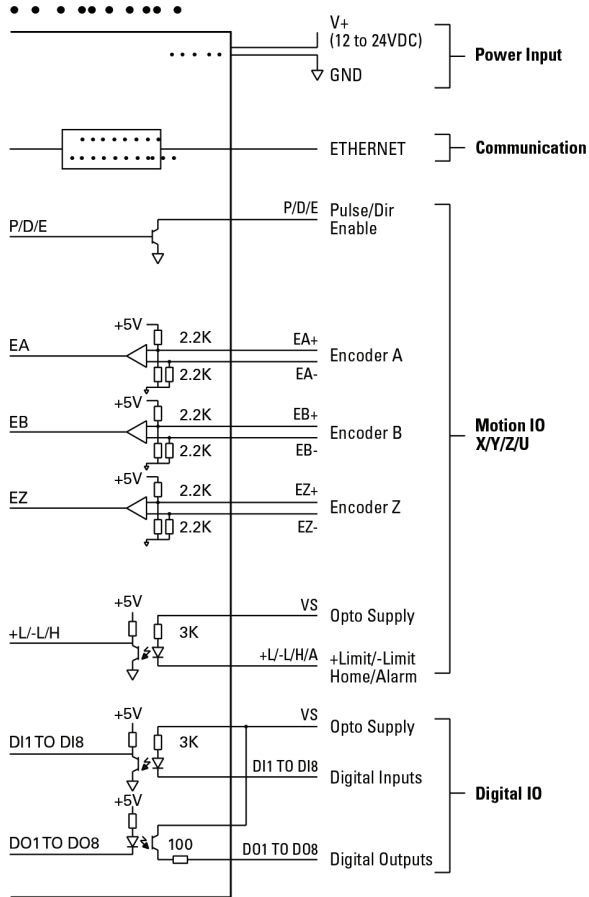

Dimensions

